

## Area Sensor

### ■ Features

- Long sensing distance up to 7m
- 22 types of products  
(Optical axis: 20/40mm, Sensing height: 120 to 940mm)
- Minimizes unsensing area with 20mm optical axis pitch (BW20-□)
- Easy to recognize at side, front, and long-distance by high brightness LED of Emitter and Receiver
- Includes self-diagnosis function, mutual interference prevention function, external diagnosis function.
- Protection structure IP65 (IEC standard)

 Please read "Caution for your safety" in operation manual before using.



### ■ Specifications

Model	NPN open collector output (standard)	BW20-08 BW20-12 BW20-16	BW20-20 BW20-24 BW20-28	BW20-32 BW20-36 BW20-40	BW20-44 BW20-48	BW40-04 BW40-06 BW40-08	BW40-10 BW40-12 BW40-14	BW40-16 BW40-18 BW40-20	BW40-22 BW40-24	
	PNP open collector output	BW20-08P BW20-12P BW20-16P	BW20-20P BW20-24P BW20-28P	BW20-32P BW20-36P BW20-40P	BW20-44P BW20-48P	BW40-04P BW40-06P BW40-08P	BW40-10P BW40-12P BW40-14P	BW40-16P BW40-18P BW40-20P	BW40-22P BW40-24P	
Sensing type	Through-beam									
Sensing distance	0.1 to 7m									
Sensing target	Opaque materials of Min.Ø30mm					Opaque materials of Min.Ø50mm				
Optical axis pitch	20mm					40mm				
Number of optical axis	8 to 48EA					4 to 24EA				
Sensing width	140 to 940mm					120 to 920mm				
Power supply	12-24VDC ±10% (Ripple P-P: Max. 10%)									
Reverse polarity protection	Built-in									
Current consumption	Emitter: Max. 80mA, Receiver: Max. 80mA									
Control output	NPN or PNP open collector output • Load voltage: Max. 30VDC • Load current: Max. 100mA • Residual voltage - NPN: Max. 1V, PNP: Min. 2.5V									
Operation mode	Light ON (fixed)									
Short-circuit protection	Built-in									
Response time	Max. 12ms									
Light source	Infrared LED (850nm modulated)									
Synchronization type	Synchronized by synchronous line									
Self-diagnosis	Ambient light monitoring, Emitter/Receiver light circuit monitoring, Output circuit monitoring									
Interference protection	Interference protection by master/slave function									
Environment	Ambient illumination	Sunlight: 10,000lx (received light side illumination)								
	Ambient temperature	-10 to 55°C, storage: -20 to 60°C								
	Ambient humidity	35 to 85%RH, storage: 35 to 85%RH								
Noise resistance	±240V the square wave noise (pulse width: 1μs) by the noise simulation									
Dielectric strength	1,000VAC 50/60Hz for 1minute									
Insulation resistance	Min. 20MΩ (at 500VDC megger)									
Vibration	1.5mm amplitude at frequency of 10 to 55Hz (for 1 min.) in each X, Y, Z direction for 2 hour									
Shock	500m/s <sup>2</sup> (approx. 50G) in each X, Y, Z direction for 3 times									
Protection structure	IP65 (IEC standard)									
Material	• Case: Aluminum • Cover, Sensing part: Acrylic									
Cable	Ø5mm, 4-core, length: 300mm, M12 connector									
Accessory	Bracket A: 4EA, Bracket B: 4EA, Fixing bolt: 8EA									
Approval										
Unit weight	Approx. 1.4kg (for 48 optical axes)									

※The temperature or humidity mentioned in Environment indicates a non freezing or condensation environment.

(A)	Photoelectric Sensors
(B)	Fiber Optic Sensors
(C)	Door/Area Sensors
(D)	Proximity Sensors
(E)	Pressure Sensors
(F)	Rotary Encoders
(G)	Connectors/ Sockets
(H)	Temperature Controllers
(I)	SSRs / Power Controllers
(J)	Counters
(K)	Timers
(L)	Panel Meters
(M)	Tacho / Speed / Pulse Meters
(N)	Display Units
(O)	Sensor Controllers
(P)	Switching Mode Power Supplies
(Q)	Stepper Motors & Drivers & Controllers
(R)	Graphic/ Logic Panels
(S)	Field Network Devices
(T)	Software

# BW Series

## Feature Data

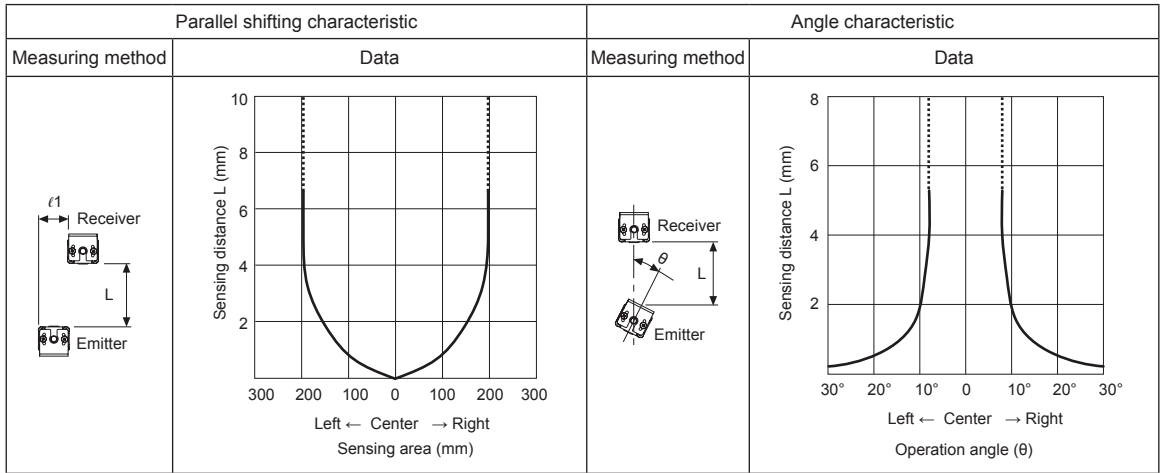

## Dimensions

(unit: mm)

<Emitter>      <Receiver>

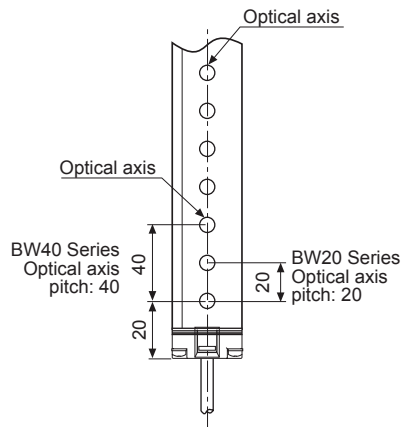
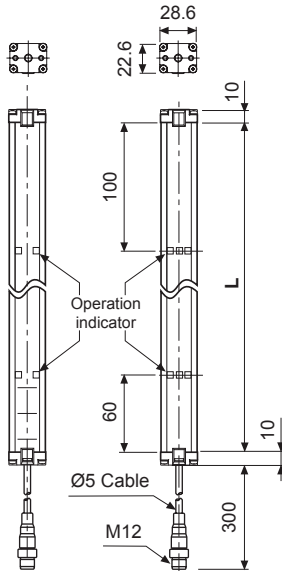

Model	L (mm)	Model	L (mm)
BW20-08 (P)	160	BW20-32 (P)	640
BW40-04 (P)		BW40-16 (P)	
BW20-12 (P)	240	BW20-36 (P)	720
BW40-06 (P)		BW40-18 (P)	
BW20-16 (P)	320	BW20-40 (P)	800
BW40-08 (P)		BW40-20 (P)	
BW20-20 (P)	400	BW20-44 (P)	880
BW40-10 (P)		BW40-22 (P)	
BW20-24 (P)	480	BW20-48 (P)	960
BW40-12 (P)		BW40-24 (P)	
BW20-28 (P)	560		
BW40-14 (P)			

### • Bracket A

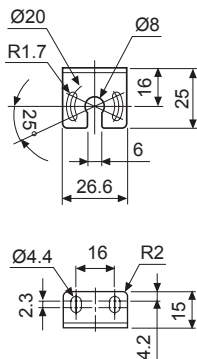

### • Bracket B

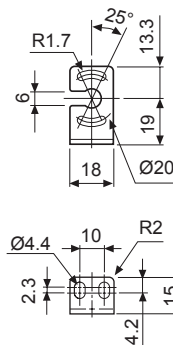

## Control Output Diagram

### • NPN open collector output

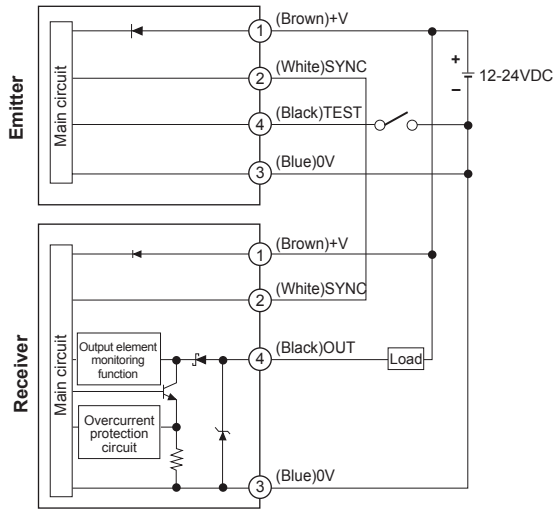

### • PNP open collector output

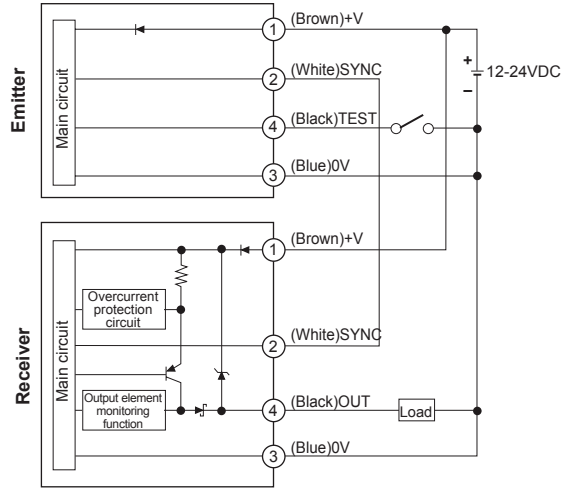

## Structure

※Upper operation indicator is set additionally, in case the number of the optical axes is more than 24EA in BW20 Series and more than 12EA in BW40 Series.

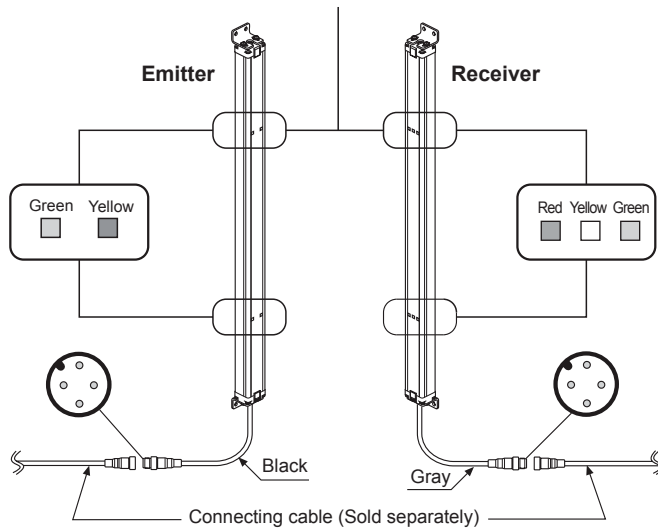

<Operation indicator >

LED color	Emitter	Receiver
Green	POWER	ON
Yellow	TEST (M/S)	UNSTABLE
Red	—	OFF

<Wiring Connection >

Pin No	Cable color	Emitter	Receiver
1	Brown	12-24VDC	12-24VDC
2	White	SYNC	SYNC
3	Blue	0V	0V
4	Black	TEST (M/S)	OUT

## Connecting Cable (Sold Separately)

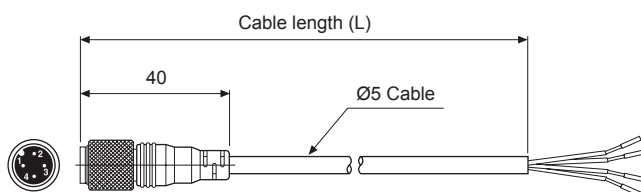

	Model	L	Cable color
Emitter	CID4-3T	3m	Black
	CID4-5T	5m	
	CID4-7T	7m	
	CID4-10T	10m	
Receiver	CID4-3R	3m	Gray
	CID4-5R	5m	
	CID4-7R	7m	
	CID4-10R	10m	

※Connecting cable is sold separately as one set; each of emitter's and receiver's.

(A) Photoelectric Sensors

(B) Fiber Optic Sensors

(C) Door/Area Sensors

(D) Proximity Sensors

(E) Pressure Sensors

(F) Rotary Encoders

(G) Connectors/ Sockets

(H) Temperature Controllers

(I) SSRs / Power Controllers

(J) Counters

(K) Timers

(L) Panel Meters

(M) Tacho / Speed / Pulse Meters

(N) Display Units

(O) Sensor Controllers

(P) Switching Mode Power Supplies

(Q) Stepper Motors & Drivers & Controllers

(R) Graphic/ Logic Panels

(S) Field Network Devices

(T) Software

# BW Series

## Bracket Mounting

• Connect the bracket A

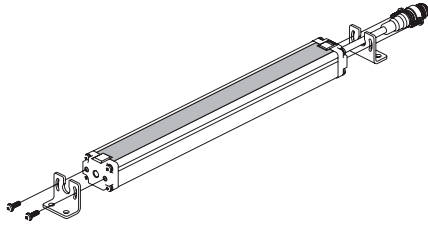

• Connect the bracket B

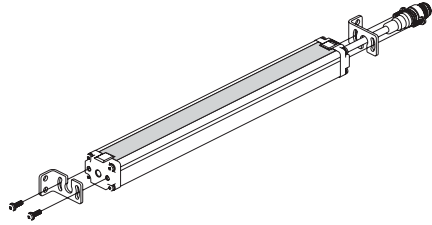

## Optical Axis Pitch/Number Of Optical Axis/Sensing Height

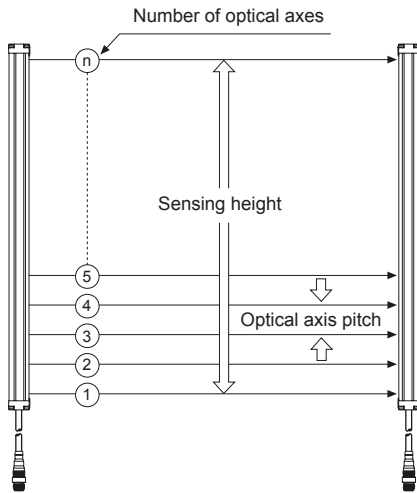

Model	Optical axis pitch
BW20-□□ (P)	20mm
BW40-□□ (P)	40mm

Model	Number of optical axis	Sensing height	Model	Number of optical axis	Sensing height
BW20-08 (P)	8	140mm	BW40-04 (P)	4	120mm
BW20-12 (P)	12	220mm	BW40-06 (P)	6	200mm
BW20-16 (P)	16	300mm	BW40-08 (P)	8	280mm
BW20-20 (P)	20	380mm	BW40-10 (P)	10	360mm
BW20-24 (P)	24	460mm	BW40-12 (P)	12	440mm
BW20-28 (P)	28	540mm	BW40-14 (P)	14	520mm
BW20-32 (P)	32	620mm	BW40-16 (P)	16	600mm
BW20-36 (P)	36	700mm	BW40-18 (P)	18	680mm
BW20-40 (P)	40	780mm	BW40-20 (P)	20	760mm
BW20-44 (P)	44	860mm	BW40-22 (P)	22	840mm
BW20-48 (P)	48	940mm	BW40-24 (P)	24	920mm

## Operation Timing Diagram

• Operation mode: Light ON only

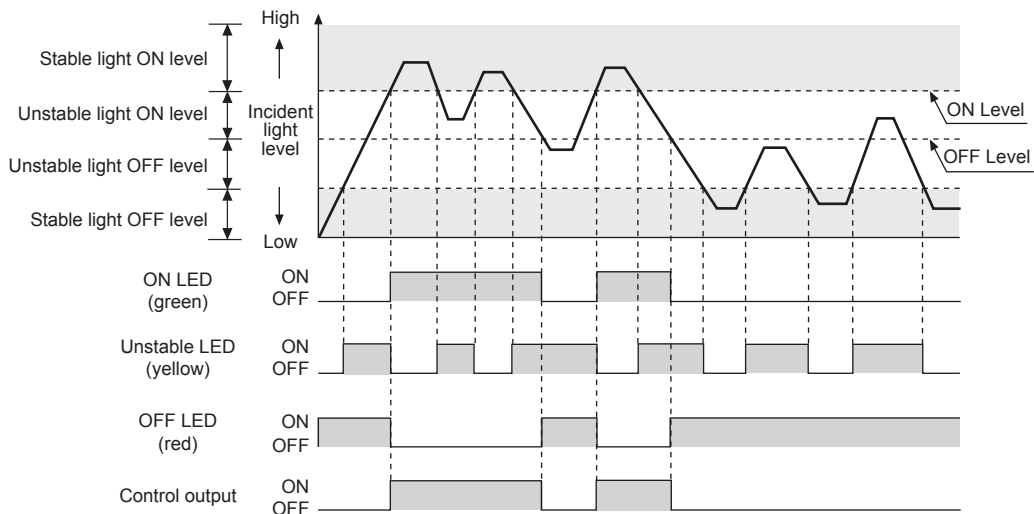

## Function

### Light emitted stop (external diagnosis)

When TEST input (black) of emitter is 0V, emit is stopped and yellow LED of emitter flashes. It is available to check whether sensor operates properly with stopping the transmission when TEST input (black) of emitter is 0V. (It is changed to light OFF status when emit the transmission is stopped, control output of receiver is OFF.)

### Connections for TEST input

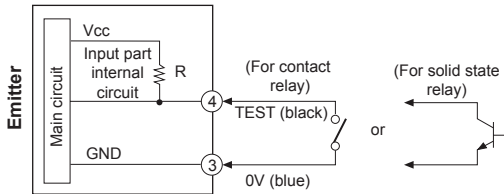

### Control output pulse by TEST input

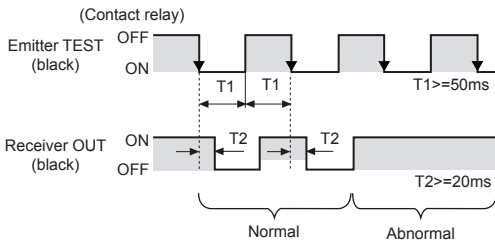

### Self-diagnosis

Control output will be OFF and operating indicator is ON when malfunction is checked by self-diagnosis regularly in normal operation.

#### Diagnosis items

- Emitter:
    - ① Break of light emitting element
    - ② Break of light emitting circuit
    - ③ Malfunction of MASTER/SLAVE line (Operation in MASTER)
  - Receiver:
    - ① Break of light receiving circuit
    - ② Break of output circuit
    - ③ Overcurrent at output part
    - ④ Synchronous line malfunction
    - ⑤ Extraneous light received
- Refer to C-26, "Operation indicator" for the display operation of diagnosis.

### Interference protection

In case of using 2 sensors in parallel in order to extend sensing width, it may cause sensing error because as light interference.

This function is operating a sensor as MASTER and another sensor as SLAVE to avoid these sensing errors by the light interference.

### Time chart for MASTER/SLAVE transmission pulse

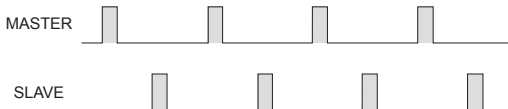

### MASTER/SLAVE connections

<NPN open collector output >

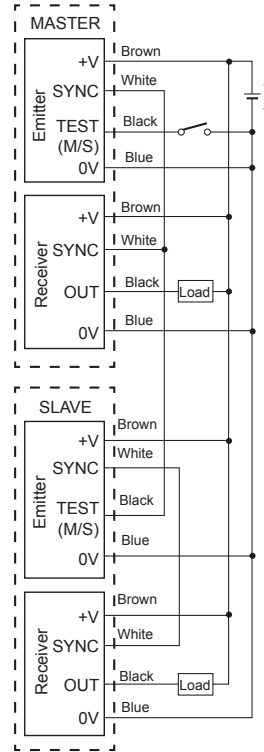

<PNP open collector output >

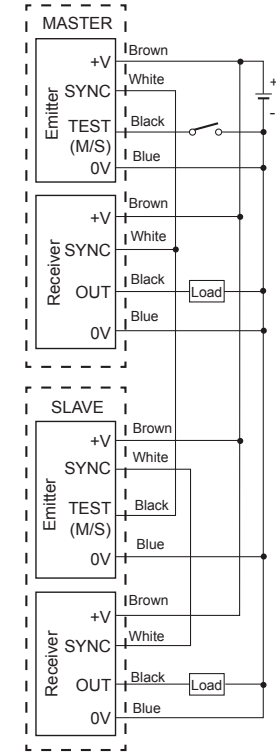

※Connect 'TEST (M/S)' of SLAVE emitter to 'SYNC' of MASTER.

## Installation

### For direction of installation

Emitter and receiver should be installed in same up/down direction.

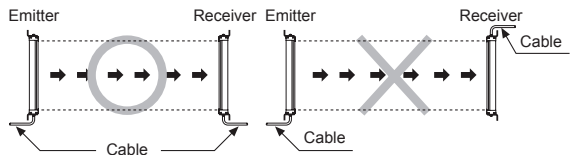

### For reflection from the surface of wall and flat

When installing it as below the light reflected from the surface of wall and flat will not be shaded. Please, check whether it operates normally or not with a sensing target before using. (Interval distance: Min. 0.5m)

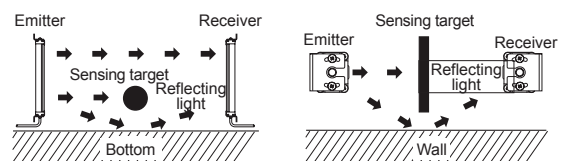

(A)	Photoelectric Sensors
(B)	Fiber Optic Sensors
(C)	Door/Area Sensors
(D)	Proximity Sensors
(E)	Pressure Sensors
(F)	Rotary Encoders
(G)	Connectors/ Sockets
(H)	Temperature Controllers
(I)	SSRs / Power Controllers
(J)	Counters
(K)	Timers
(L)	Panel Meters
(M)	Tacho / Speed / Pulse Meters
(N)	Display Units
(O)	Sensor Controllers
(P)	Switching Mode Power Supplies
(Q)	Stepper Motors & Drivers & Controllers
(R)	Graphic/ Logic Panels
(S)	Field Network Devices
(T)	Software

# BW Series

## ◎ For prevention of interference

It may cause interference when installing more than 2 sets of the sensor. In order to avoid the interference of the sensor, please install as following figures and use the interference protection function.

### ● Transmission direction should be opposite between 2 sets

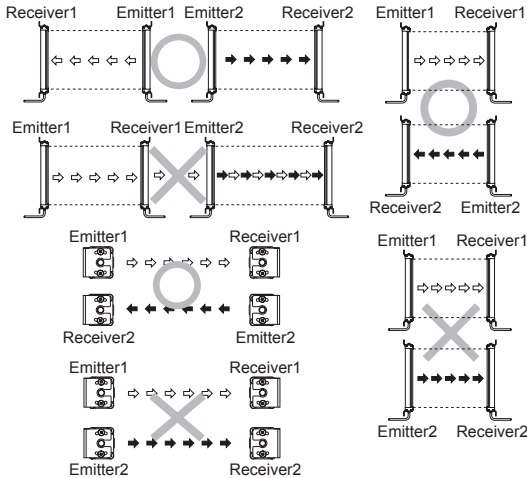

### ● Baffle should be installed between 2 sets

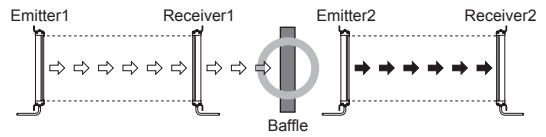

### ● It should be installed out of the interference distance

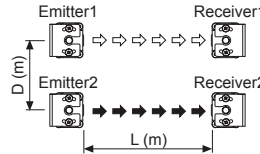

Sensing distance (L)	Installation allowable distance (D)
0.1 to 3m	Min. 0.4m
Min. 3m	$L \times \tan 8^\circ = L \times 0.14$ min

※There can be a little different based on installation environment.

## ■ Operation Indicator

Item	Emitter		Receiver			Control output
	Indicator	Indicator	Indicator	Indicator	Indicator	
	Green	Yellow	Green	Yellow	Red	
Power on	☀	●	—	—	—	—
MASTER operation	☀	●	—	—	—	—
SLAVE operation	☀	☀	—	—	—	—
Test input	☀	◐	—	—	—	OFF
Break of light emitting element	▶	◀	—	—	—	OFF
Break of light emitting circuit	◐	◐	—	—	—	OFF
Stable light ON	—	—	☀	●	●	ON
Unstable light ON	—	—	☀	☀	●	ON
Unstable light OFF	—	—	●	☀	☀	OFF
Stable light OFF	—	—	●	●	☀	OFF
Break of light receiving circuit	—	—	●	▶	◀	OFF
Break of output element	—	—	▶	◀	●	OFF
Synchronous line malfunction	—	—	▶	●	◀	OFF
Overcurrent	—	—	◐	◐	◐	OFF
Extraneous light received	—	—	●	◐	◐	OFF
Breakdown of emitter	—	—	▶	▶	▶	OFF

Display classification list	
☀	Light ON
●	Light OFF
◐	Flashing by 0.5 sec.
◐ or ◐	Flashing simultaneously by 0.5 sec.
▶ ◀	Cross-Flashing by 0.5 sec.
▶ ▶ ▶	Sequence-Flashing by 0.5 sec.

## ■ Troubleshooting

Malfunction	Cause	Troubleshooting
Non-operation	Power supply	Supply rated power.
	Cable incorrect connection or disconnection	Check the wiring.
	Rated connection failure	Use it within rated sensing distance.
Non-operation in sometimes	Pollution by dirt of sensor cover	Remove dirt by soft brush or cloth.
	Connector connection failure	Check the assembled part of the connector.
Control output is OFF even though there is not a target object.	Out of rated sensing distance	Use within rated sensing distance.
	There is an obstacle to cut off the light emitted between emitter and receiver	Remove the obstacle.
	There is a strong electric wave or noise generated by motor, electric generator, high voltage line etc.)	Put away the strong electric wave or noise generator.
LED displays for break of light emitting element	Break of light emitting element	Contact our company.
LED displays for break of light emitting circuit	Break of light emitting circuit	
LED displays for break of light receiving element	Break of light emitting receiving element	
LED displays for break of output element	Break output element	Contact our company.
LED displays for synchronous line malfunction	Synchronous line incorrect connection or disconnection Break of synchronous circuit of emitter or receiver	
LED displays for over current	Control output line is shorten	Check the wiring.
	Over load	Check the rated load capacity.
LED displays for ambient light receiving	Ambient light received to receiver	Remove the ambient light.
LED displays for emitter malfunction	Emitter malfunction	Treat after checking the emitter display LED.