

PROVEN PERFORMANCE

Customers in over 60 countries and in diverse markets and sectors.



Motion Control
Servo System

Low-voltage Servo System Catalog

- FD1X4S Servo Driver
- FD1X3 Servo Driver
- Low-voltage Servo Motor
- MD series integrated Servo Motor





- 02 **preface**
Logistics warehouse system:Multi-shuttle robot
Handling system:Intelligent warehouse robot
Sorting system:High-speed cross-belt sorting machine
- 03 **Brief Introduction of Low Voltage Servo Driver and Motor**
FD1X4S&FD1X3 servo driver
New generation innovative-structure motor
- 04 **Model description/Model list**
FD series Model description
Servo motor
Motor power cable, encoder cable, brake cable
- 07 **Driver and Motor Configuration Table**
FD1X4S Driver and Motor Configuration Table
FD1X3 Driver and Motor Configuration Table
- 09 **FD1X4S series servo driver**
Technical parameter table
Interface description
Description of communication terminal
Wiring Diagram of IO Terminal X3
Mechanical dimension drawing
- 16 **FD1X3 series servo driver**
Technical parameter table
Interface description
De scription of communication terminal
Wiring Diagram of IO Terminal X3
Mechanical dimension drawing
- 22 **Low voltage servo motor**
 - SMC series Servo Motor (Magnetolectric encoder)
Technical Specifications table/mechanical dimension drawing/motor torque curve
 - SMC series Servo Motor (incremental encoder)
Technical Specifications table/mechanical dimension drawing/motor torque curve
 - SMH series Servo Motor (incremental encoder)
Technical Specifications table/mechanical dimension drawing/motor torque curve
 - SMS series Servo Motor (Multi-turn absolute encoder)
Technical Specifications table/mechanical dimension drawing/motor torque curve
- 33 **Cable**
Encoder cable/Brake cable/Power cable
- 38 **MD series integrated servo motor**
Type description
MD Technical Specifications Table
Wiring port description
Mechanical Ruler Drawing

Now, with the rapid development of Chinese E-Business, it causes rising-up of intelligent logistics industry all over the world. Logistics device suppliers all aim to the time of industry development and develop lots of new logistics warehouse products. Among them, Multi-shuttle, intelligent warehouse handling and high-speed cross-belt sorting will cause further logistics industry's transform. Kinco, as the leading suppliers of machine automation and intelligence factory solutions in China, focus on characteristics of logistics industry automation and develops dedicated servo system used in logistics automation industry, which helps to make a transform in logistics automation.

Logistics warehouse system: Multi-shuttle robot

Multi-shuttle system is mainly made up of multi-shuttle robot, double-station bin elevator, vehicle elevator and double-station shelf system. Multi-shuttle robot is new generation automatic access solution device, which is suitable for access of carton, container and small tray. It is different from traditional automatic access system. Multi-shuttle use intelligent cargo car on the first floor or between multiple floors according to requirements so as to decrease the cost and efficiently use warehouse space.

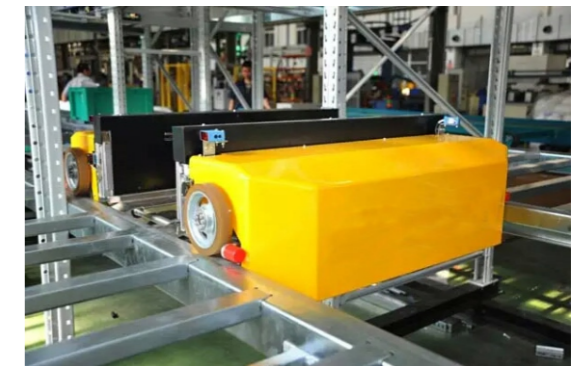

Handling system: Intelligent warehouse robot

Intelligent warehouse robot is new product in order to satisfy shelf provisioning, sorting and integration in big warehouse workshop. This product truly achieves "shelf-to-people" working mode. It is mainly made up of robot, virtual navigation sensors and etc. Intelligent warehouse robot can lift shelves which are filled goods or books and send shelves to specified position rapidly and steadily. After operation is finished, it will automatically put shelves to specified positions and wait for next task. Users can sort out goods according to category under control of control desk and put goods in the same category into one shelf, which decreases shipping time of goods and sharply increases warehouse efficiency.

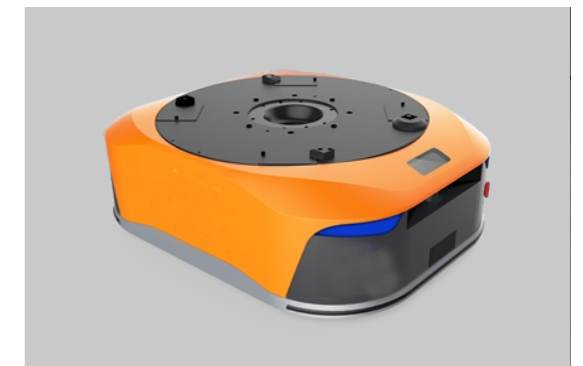

Sorting system: High-Speed cross-belt sorting machine

Main drive belt conveyor connects with trolley loading small belt conveyor (Abbreviation: car). When "car" move to required sorting position, rotating the belt to finish sorting tasks. As main drive belt conveyor cross with belt conveyor in "car", this is named cross-belt sorting machine. It is suitable for sorting all kinds of small goods. So it sharply increases sorting task's efficiency and accuracy. And it also reduces worker's task strength. It has great market prospect in E-Business, delivery, clothing and etc. Main driver use linear motor, which is good at big driving force, high speed, steady running and low noise. For "car", it uses low-voltage servo drive, which has rapid response and short sorting time.





FD1X4S&FD1X3 servo driver

- Smaller size:** size of the whole machine decreases from 146*95*39 to 141*76*25 mm. There is a 50% decrease in space, which meets with requirement of AGV space.
- Better over-load:** For 750W driver, its output current increases from 50Ap to 80Ap, There is a 50% increase in driving ability, which enhances AGV car's over-load ability and acceleration.
- More functions:** Alarm synchronous braking, 24V brake power supply output, better battery duration and functional requirements of AGV space.
- Stronger communication ability:** Support CANopen, EtherCAT and etc. Can work together with NDC, Beckhoff and other famous controller.

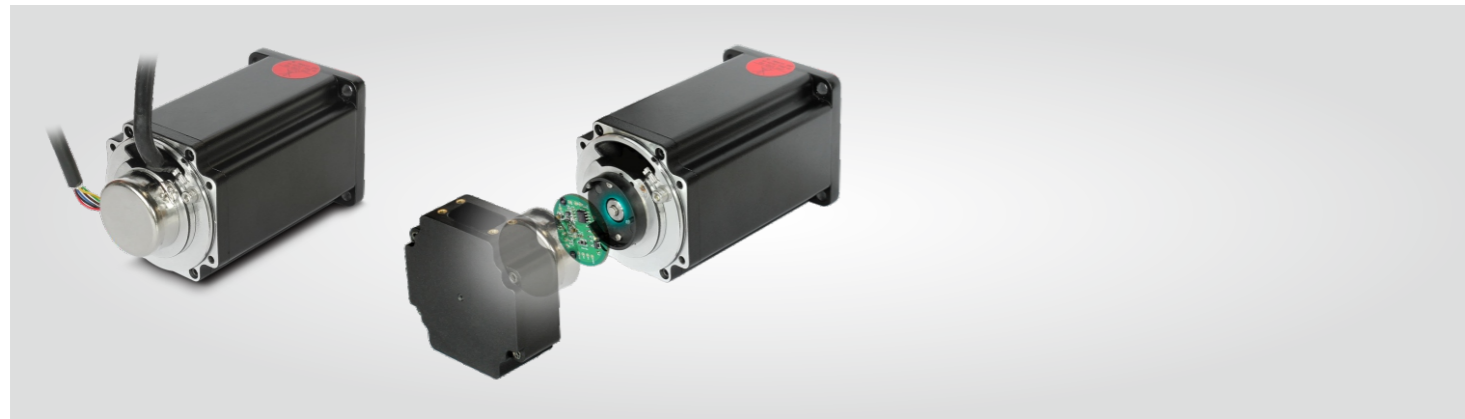

New generation innovative-structure motor

- Innovative structure:** New generation & new mold design of motor structure, short length of motor.
- The latest magnetolectric technology:** New magnetolectric encoder designed by Kinco, better cushioning ability & higher cost-performance.
- Insulation class F:** Highest insulation class of motor in the industry. Motor have quiet high reliability and stability in high temperature environment.
- Wide range of power:** The power of motor up to 1.5Kw under DC 48V of power supply, rated speed is 3000RPM, suitable to heavy-load AGV occasion.

FD series Model description

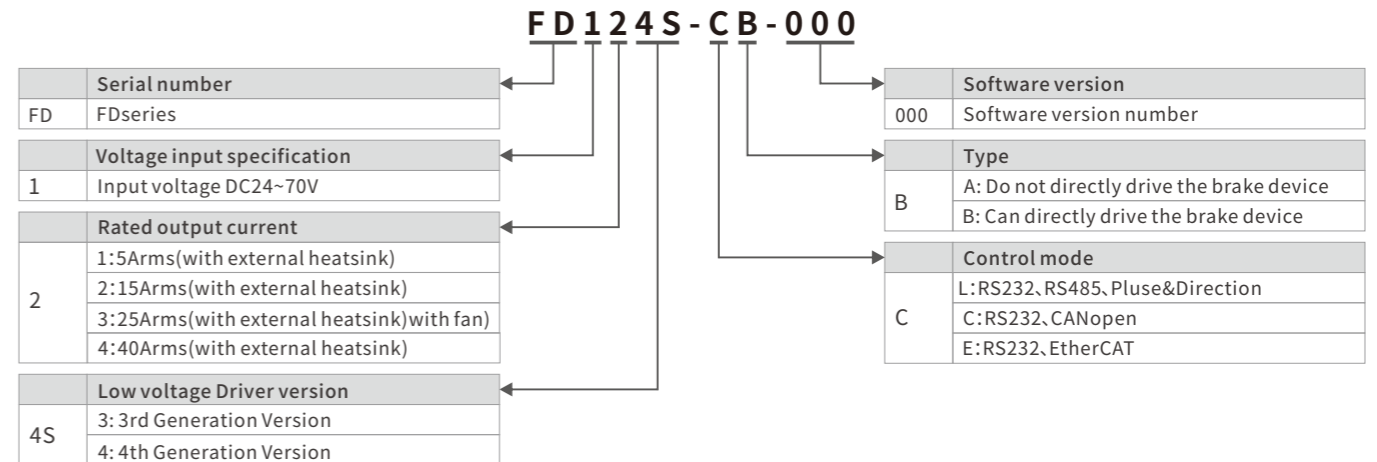

FD series model list

Series	model	Power	Rated current (Arms)	peak current (PEAK)	control model	Brake power supply	24V Logic Power Supply	Weight (Kg)	Mechanical dimensions (mm)		
FD1X4S series DC48V	FD114S-LB-000	50~100W	5Arms	8Ap	RS485, pulse	●	○	0.3	141x75.5x25.4		
	FD114S-CB-000				CANopen	●	●				
	FD114S-EB-000				EtherCAT	●	●				
	FD124S-LA-000	200~400W	15Arms (Up to 12Arms without auxiliary radiator)	48Ap	RS485, pulse	○	○	0.3	141x75.5x25.4		
	FD124S-LB-000				CANopen	●	○				
	FD124S-CA-000				EtherCAT	○	●				
	FD124S-CB-000					●	●				
	FD124S-EA-000					○	●				
	FD124S-EB-000					●	●				
	FD134S-LA-000	750W	25Arms (Up to 20Arms without auxiliary radiator)	80Ap	RS485, pulse	○	○	0.6	174.6x100.5x31		
	FD134S-LB-000				CANopen	○	●				
	FD134S-CA-000				EtherCAT	●	●				
FD134S-CB-000					○	●					
FD134S-EA-000					○	●					
FD134S-EB-000					●	●					
FD144S-LA-000	1.2~1.5kW	40Arms (Up to 30Arms without auxiliary radiator)	120Ap	RS485, pulse	○	○	0.9	200x100.5x35.8			
FD144S-LB-000				CANopen	○	●					
FD144S-CA-000				EtherCAT	●	●					
FD144S-CB-000					○	●					
FD144S-EA-000					○	●					
FD144S-EB-000					●	●					
FD1X3 series DC48V	FD123-LA-000	200~400W	10Arms	45Ap	RS485, pulse	○	●	0.8	150x95x39.5		
	FD123-CA-000				CANopen, pulse						
	FD123-EA-000				EtherCAT, pulse						
	FD123-LA-003				RS485, pulse, Matching Multi-turn absolute encoder motor						
	FD123-CA-003				CANopen, pulse, Matching Multi-turn absolute value encoder motor						
	FD123-EA-003				EtherCAT, pulse, Matching Multi-turn absolute encoder motor						
	FD123-LA-000	750W	20Arms	50Ap	RS485, pulse			○	●	1.2	188x97.5x52
	FD133-CA-000				CANopen, pulse						
	FD133-EA-000				EtherCAT, pulse						
	FD133-LA-003				RS485, pulse, Matching Multi-turn absolute encoder motor						
	FD133-CA-003				CANopen, pulse, Matching Multi-turn absolute encoder motor						
	FD133-EA-003				EtherCAT, pulse, Matching Multi-turn absolute encoder motor						

note: ● with brake; ○ without brake

Model description/Model list

Model description of servo motor

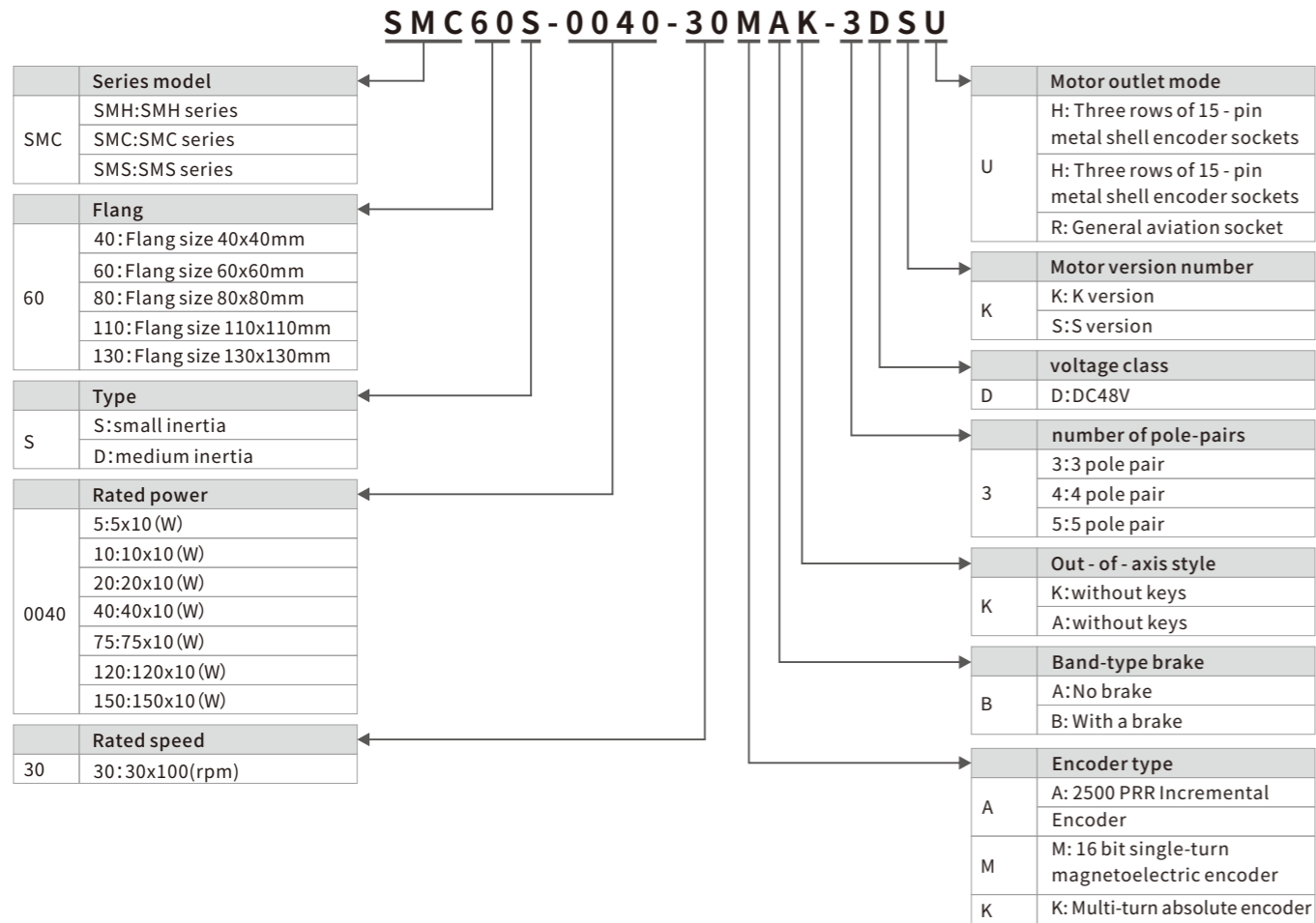

SMC Series Servo Motor Model List

series	model	rated power Pn	rated torque Tn(Nm)	rated speed n _n (rpm)	rated current I _n (A)	diameter of axle(mm)	length of motor (mm)		
							□=A	□=B (motor with brake)	
Magnetoelectric Encoder	SMC40S-0005-30M□K-5DSU	50W	0.16	3000	1.5	8	74.6±1.5	104.6±1.5	
	SMC40S-0010-30M□K-5DSU	100W	0.32		3.2		96.6±1.5	126.6±1.5	
	SMC60S-0020-30M□K-3DSU	200W	0.64		14	5.1	91±1.5	121±1.5	
	SMC60S-0040-30M□K-3DSU	400W	1.27			10.1	117±1.5	147±1.5	
	SMC80S-0075-30M□K-3DSU	750W	2.39			19	128.5±1.5	158±1.5	
Multi-turn absolute value Encoder	SMS60S-0020-30K□K-3DSU	200W	0.64		14	5.1	91±1.5	121±1.5	
	SMS60S-0040-30K□K-3DSU	400W	1.27			10.1	117±1.5	147±1.5	
	SMS80S-0075-30K□K-3DSU	750W	2.39		19	19	128.5±1.5	158±1.5	
	SMC60S-0020-30A□K-3DSH	200W	0.64			14	5.1	104±1.5	150±1.5
	SMC60S-0040-30A□K-3DSH	400W	1.27				10.1	130±1.5	176±1.5
Incremental Encoder	SMC80S-0075-30A□K-3DSH	750W	2.39	19	19	140±1.5	187±1.5		
	SMC130D-0120-30A□K-4DKR	1.2kW	3.8		22	31.6	147±1.5	163±1.5	
	SMC130D-0150-30A□K-4DKR	1.5kW	5	37.4		208±1.5	224±1.5		
	SMH110D-0120-30A□K-4DKR	1.2kW	4	32	19	168±1.5	228±1.5		

Model description/Model list

Motor power cable, encoder cable, brake cable

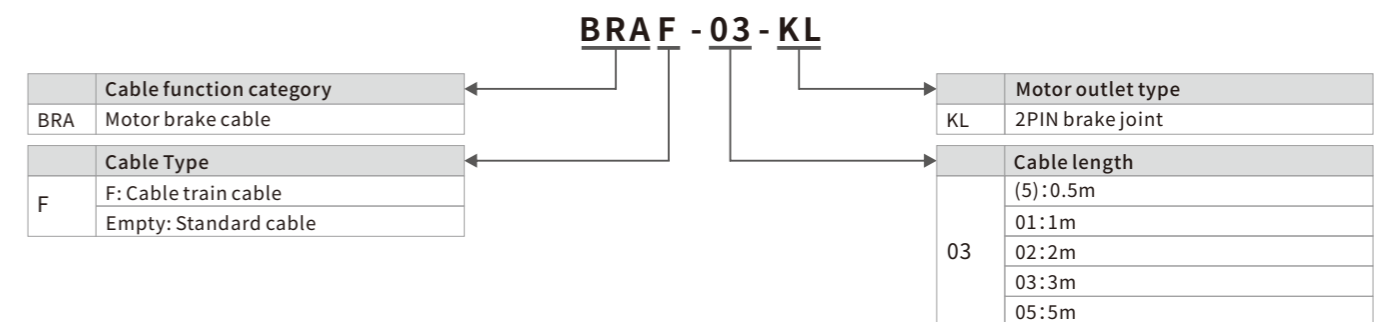
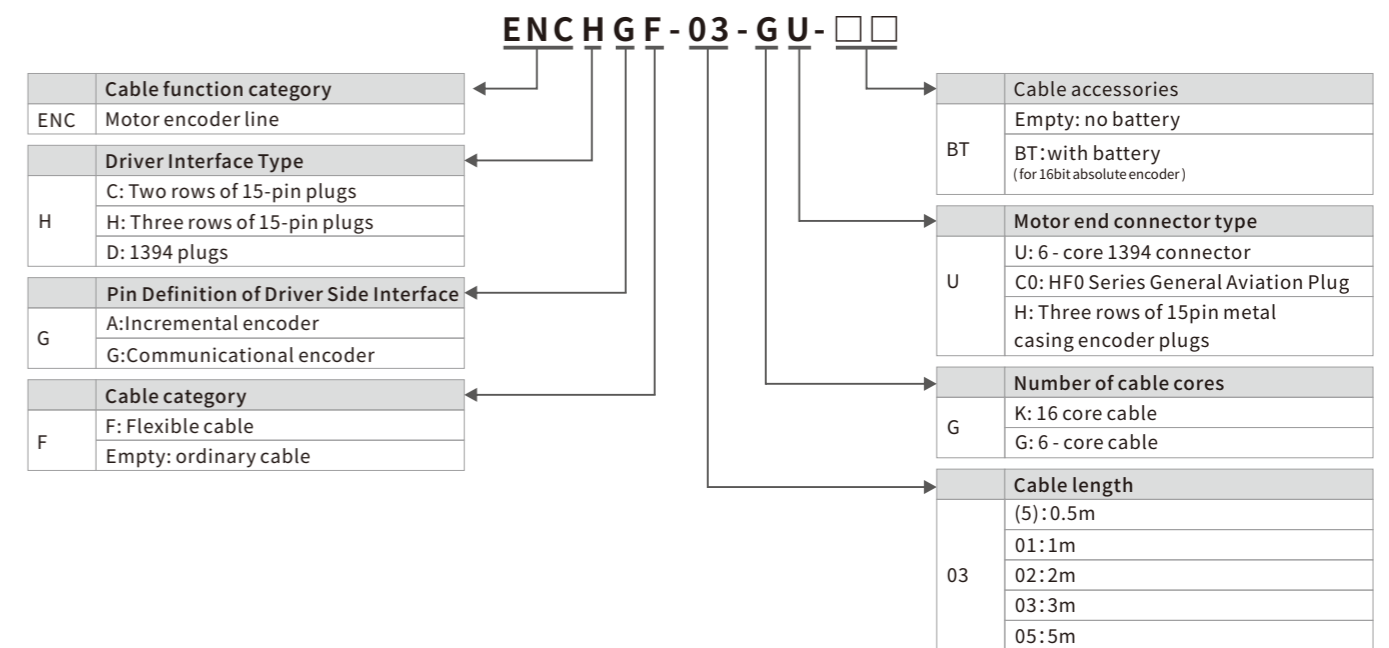
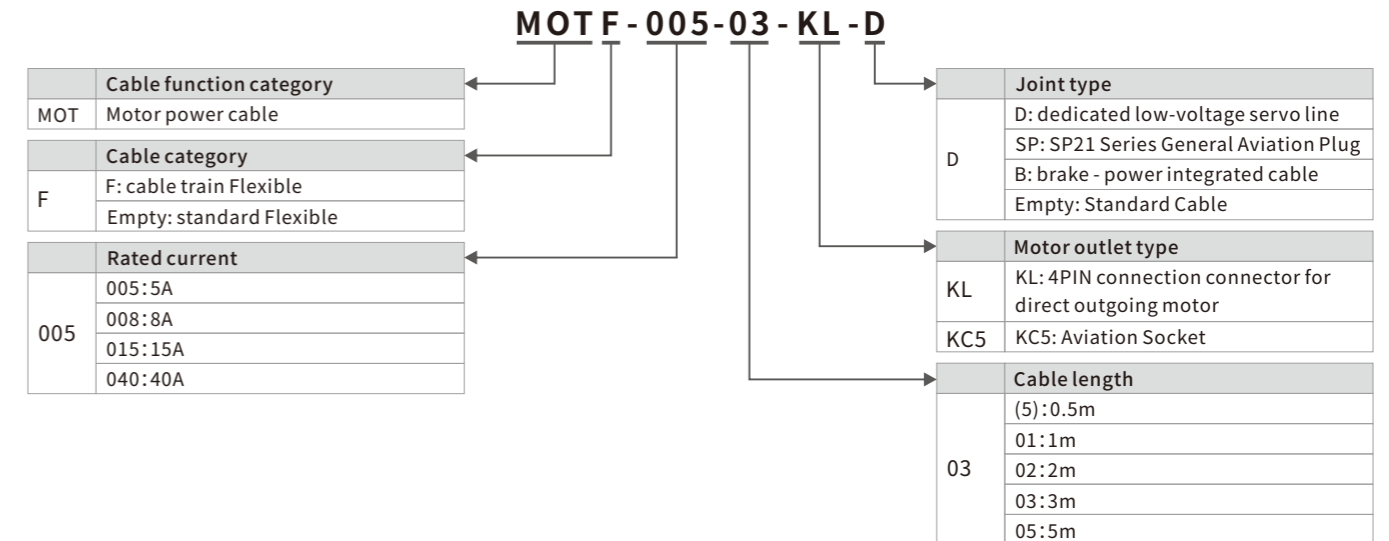

Driver and Motor Configuration Table

Driver and Motor Configuration Table

FD1X4S Servo Driver and Motor Selection Table

Category	Rated power/ Rated speed/ Rated torque/	Servo Motor	Description	Power/ Brake Cable	Encoder Cable	Servo Driver			
						CANopen	EtherCAT	Pulse/MODBUS 485	
Small Inertia DC48V	50W 3000rpm 0.16Nm	SMC40S-0005-30MAK-5DSU	16 bit single-turn magnetoelectric encoder	MOT-005-LL-KL-D	ENCHG-LL-GU	FD114S-CB-000	FD114S-EB-000	FD114S-LB-000	
		SMC40S-0005-30MBK-5DSU	16 bit single-turn magnetoelectric encoder with brake	MOT-005-LL-KL-D/BRA-LL-KL					
	100W 3000rpm 0.32Nm	SMC40S-0010-30MAK-5DSU	16 bit single-turn magnetoelectric encoder	MOT-005-LL-KL-D					
		SMC40S-0010-30MBK-5DSU	16 bit single-turn magnetoelectric encoder with brake	MOT-005-LL-KL-D/BRA-LL-KL					
	200W 3000rpm 0.64Nm	SMC60S-0020-30MAK-3DSU	16 bit single-turn magnetoelectric encoder	MOT-005-LL-KL-D					
		SMC60S-0020-30MBK-3DSU	16 bit single-turn magnetoelectric encoder with brake	MOT-005-LL-KL-D/BRA-LL-KL					
	400W 3000rpm 1.27Nm	SMC60S-0040-30MAK-3DSU	16 bit single-turn magnetoelectric encoder	MOT-008-LL-KL-D					
		SMC60S-0040-30MBK-3DSU	16 bit single-turn magnetoelectric encoder with brake	MOT-008-LL-KL-D/BRA-LL-KL					
	750W 3000rpm 2.39Nm	SMC80S-0075-30MAK-3DSU	16 bit single-turn magnetoelectric encoder	MOT-015-LL-KL-SP					
		SMC80S-0075-30MBK-3DSU	16 bit single-turn magnetoelectric encoder with brake	MOT-015-LL-KL-SP/BRA-LL-KL					
	200W 3000rpm 0.64Nm	SMC60S-0020-30AAK-3DSH	2500P/R incremental encoder , lead cable	MOT-005-LL-KL-D		ENCHA-LL-KH	FD124S-CA-000	FD124S-EA-000	FD124S-LA-000
		SMC60S-0020-30ABK-3DSH	2500P/R incremental encoder with brake , lead cable	MOT-005-LL-KL-D/BRA-LL-KL			FD124S-CB-000	FD124S-EB-000	FD124S-LB-000
400W 3000rpm 1.27Nm	SMC60S-0040-30AAK-3DSH	2500P/R incremental encoder , lead cable	MOT-008-LL-KL-D	FD124S-CA-000	FD124S-EA-000		FD124S-LA-000		
	SMC60S-0040-30ABK-3DSH	2500P/R incremental encoder with brake , lead cable	MOT-008-LL-KL-D/BRA-LL-KL	FD124S-CB-000	FD124S-EB-000		FD124S-LB-000		
750W 3000rpm 2.39Nm	SMC80S-0075-30AAK-3DSH	2500P/R incremental encoder , lead cable	MOT-015-LL-KL-SP	FD134S-CA-000	FD134S-EA-000		FD134S-LA-000		
	SMC80S-0075-30ABK-3DSH	2500P/R incremental encoder with brake , lead cable	MOT-015-LL-KL-SP/BRA-LL-KL	FD134S-CB-000	FD134S-EB-000		FD134S-LB-000		
Medium inertia DC48V	1260W 3000rpm 4Nm	SMH110D-0120-30AAK-4DKR	2500P/R incremental encoder, connector	MOT-040-LL-KC5	FD144S-CA-000		FD144S-EA-000	FD144S-LA-000	
		SMH110D-0120-30ABK-4DKR	2500P/R incremental encoder with brake ,connector	MOT-040-LL-KC5-B	FD144S-CB-000		FD144S-EB-000	FD144S-LB-000	
	1200W 3000rpm 3.8Nm	SMC130D-0120-30AAK-4DKR	2500P/R incremental encoder, connector	MOT-040-LL-KC5	FD144S-CA-000		FD144S-EA-000	FD144S-LA-000	
		SMC130D-0120-30ABK-4DKR	2500P/R incremental encoder with brake,connector	MOT-040-LL-KC5-B	FD144S-CB-000		FD144S-EB-000	FD144S-LB-000	
	1500W 3000rpm 5Nm	SMC130D-0150-30AAK-4DKR	2500P/R incremental encoder, connector	MOT-040-LL-KC5	FD144S-CA-000		FD144S-EA-000	FD144S-LA-000	
		SMC130D-0150-30ABK-4DKR	2500P/R incremental encoder with brake,connector	MOT-040-LL-KC5-B	FD144S-CB-000		FD144S-EB-000	FD144S-LB-000	

FD1X3 Servo Driver and Motor Selection Table

Category	Rated power/ Rated speed/ Rated torque/	Servo Motor	Description	Power/ Brake Cable	Encoder Cable	Servo Driver			
						CANopen	EtherCAT	Pulse/MODBUS 485	
Small Inertia DC48V	200W 3000rpm 0.64Nm	SMC60S-0020-30AAK-3DSH	2500P/R incremental encoder	MOT-005-LL-KL-D	ENCCA-LL-KH	FD123-CA-000	FD123-EA-000	FD123-LA-000	
		SMC60S-0020-30ABK-3DSH	2500P/R incremental encoder with brake	MOT-005-LL-KL-D/BRA-LL-KL					
	400W 3000rpm 1.27Nm	SMC60S-0040-30AAK-3DSH	2500P/R incremental encoder	MOT-008-LL-KL-D					
		SMC60S-0040-30ABK-3DSH	2500P/R incremental encoder with brake	MOT-008-LL-KL-D/BRA-LL-KL					
	750W 3000rpm 2.39Nm	SMC80S-0075-30AAK-3DSH	2500P/R incremental encoder	MOT-015-LL-KL-SP					
		SMC80S-0075-30ABK-3DSH	2500P/R incremental encoder with brake	MOT-015-LL-KL-SP/BRA-LL-KL					
	200W 3000rpm 0.64Nm	SMS60S-0020-30KAK-3DSU	Multi-turn absolute encoder"	MOT-005-LL-KL-D		ENCCG-(4)-GU-BT / ENCDG-LL-GU	FD123-CA-003	FD123-EA-003	FD123-LA-003
		SMS60S-0020-30KBK-3DSU	Multi-turn absolute encoder with brake"	MOT-005-LL-KL-D/BRA-LL-KL					
	400W 3000rpm 1.27Nm	SMS60S-0040-30KAK-3DSU	Multi-turn absolute encoder	MOT-008-LL-KL-D					
		SMS60S-0040-30KBK-3DSU	Multi-turn absolute encoder with brake	MOT-008-LL-KL-D/BRA-LL-KL					
750W 3000rpm 2.39Nm	SMS80S-0075-30KAK-3DSU	Multi-turn absolute encoder	MOT-015-LL-KL-SP						
	SMS80S-0075-30KBK-3DSU	Multi-turn absolute encoder with brake	MOT-015-LL-KL-SP/BRA-LL-KL						
FD133-CA-003	FD133-EA-003	FD133-LA-003							

Technical Parameter Table

Model Parameter	FD114S-□B-000	FD124S-□■-000	FD134S-□■-000	FD144S-□■-000
Main supply voltage	DC24V~70V			
Rated output current	Rated current (rms)	5Arms	15Arms (Up to 12Arms without auxiliary radiator)	25Arms (Up to 20Arms without auxiliary radiator)
	Peak current (PEAK)	8A	48A	80Ap
Feedback signal	5V Incremental differential encoder: 16 bit Single-turn magnetoelectric encoder;			
Brake chopper	Via wiring an external braking resistor (mainly in quick start and stop application), brake chopper threshold is 73V(Adjustable via software).			
Brake chopper threshold	DC73V ± 2V (Default value, Adjustable via software)			
Over-voltage alarming threshold	DC83V ± 2V			
Under-voltage alarming threshold	DC18V ± 2V			
Cooling method	Natural air cooling Note: The continuous output current of FD124S, FD134S, FD144S are bigger than 15Arms, 25Arms and 40Arms respectively. (Measured value on 6063 aluminum plate with oxidized auxiliary radiator, The size of auxiliar300mm*300mm*10mm)			
Weight (Kg)	0.3	0.3	0.6	0.9
General functions	Input specification	3 digital inputs, with COM1 terminal for PNP(high level valid 12.5~30V) or NPN (low level valid 0~5V) connection, input current 4 ~ 20mA, suitable to FD1X4S-□B-000 4 digital inputs, with COM1 terminal for PNP(high level valid 12.5~30V) or NPN (low level valid 0~5V) connection, input current 4 ~ 20mA, suitable to FD1X4S-□A-000		
	Input function	Define freely according to requirement, supporting following functions: Driver enable, driver fault reset, driver mode control, speed loop proportional control, positive limit, negative limit, homing signal, reverse command, internal speed section control, internal positive section control, quick stop, start homing, active command, switch electronic gear ratio, switch gain		
	Output specification	1 digital output with out 1 driving capacity of 100 mA or br + / br -) can directly drive the standard brake motor for FD1X4S - □ B - 000, please refer to the wiring port for details 2 digital outputs with out 1 out 2 driving capacity of 100 mA, suitable for FD1X4S - □ A - 000		
	Pulse direction control	Pulse + direction、CCW+CW、phase A+phase B (5V~24V) Note: Only FD1X4-L□-000 support this function		
	Output function	Define freely according to requirement, supporting following functions: Driver ready, driver fault, position reached, motor zero speed, motor brake, motor speed reached, Z signal, maximum speed obtained in torque mode, motor brake, position limiting, reference found.		
	RS232	The default baudrate is 38400. The MAX. baudrate is 115.2KHz. Use Kinco software to connect or use free protocol to communicate with controller		
	Protection function	Over-voltage protection, under-voltage protection, motor over-heat protection (I ² T), short-circuit protection, drive over-heat protection, etc.		
Bus function	Modbus/RS485	The max. baudrate is 115.2KHz, use Modbus RTU protocol to communicate with controller.		
	CAN BUS	Support maximum 1MHz baudrate. Communicate with controller via CANopen protocol		
	EtherCAT	Support CoE(CiA402 protocol) and CSP/CSV/PP/PV/PT/HM mode, Communication speed 100M.		
Operation Environment	Operation temperature	0~40°C		
	Storage temperature	-10~70°C		
	Humidity(non-condensing)	Below 90%RH		
	Protection class	IP20		
	Installation environment	Installed in a dust-free, dry and lockable environment (such as in a electrical cabinet)		
	Installation mode	Vertical installation or horizontal installation		
	Height	Rated working altitude at 1000m or below, Above 1000m: Dcreasing 1.5% per 100m rise, maximum altitude 4000m		
Atmospheric pressure	86kpa~106kpa			

Nota ①: 1: □=L: Communication port RS232、RS485、pulse
□=C: Communication port RS232、CANopen
□=E: Communication port RS232、Ethercat
2: ■=A: Cannot directly drive brake, motor holding
brake needs external power supply device
■=B: Can directly drive brake

Nota ②: FD114S-□B-000&FD124S-□B-000, input current of brake port is 0.5A
FD134S-□B-000, input current of brake port is 0.8A
FD144S-□B-000, input current of brake port is 1A

FD1X4S Interface Instructions

X1: bus interface

The following buses are supported according to the model:
- Can bus
- Modbus/RS485 bus
- EtherCAT bus

dip switch

Set the communication ID and CAN bus terminal resistance of FD1X4S driver

X2: RS232 communication interface

Connect to KincoServo+ after connecting to RS232 communication line

X3: I/O interface

- Digital signal input interface:
4 digital signal inputs
- Digital signal output interface:
2 digital signal output or 1 digital signal output & 1-way brake power output
- Control signal input interface:
Pulse direction or CW/CCW signal input

X5

DC+, DC-: DC power input (24~70V)
U、V、W、PE:
Connect the motor power cable
RB+、RB-:
External brake resistor



X5 of FD114S/FD124S



X5 of FD134S/FD144S

Note: the port X5 of FD114S\FD124S are the same, and the port X5 of FD134S\FD144S are the same.

FD1X4S Port Description

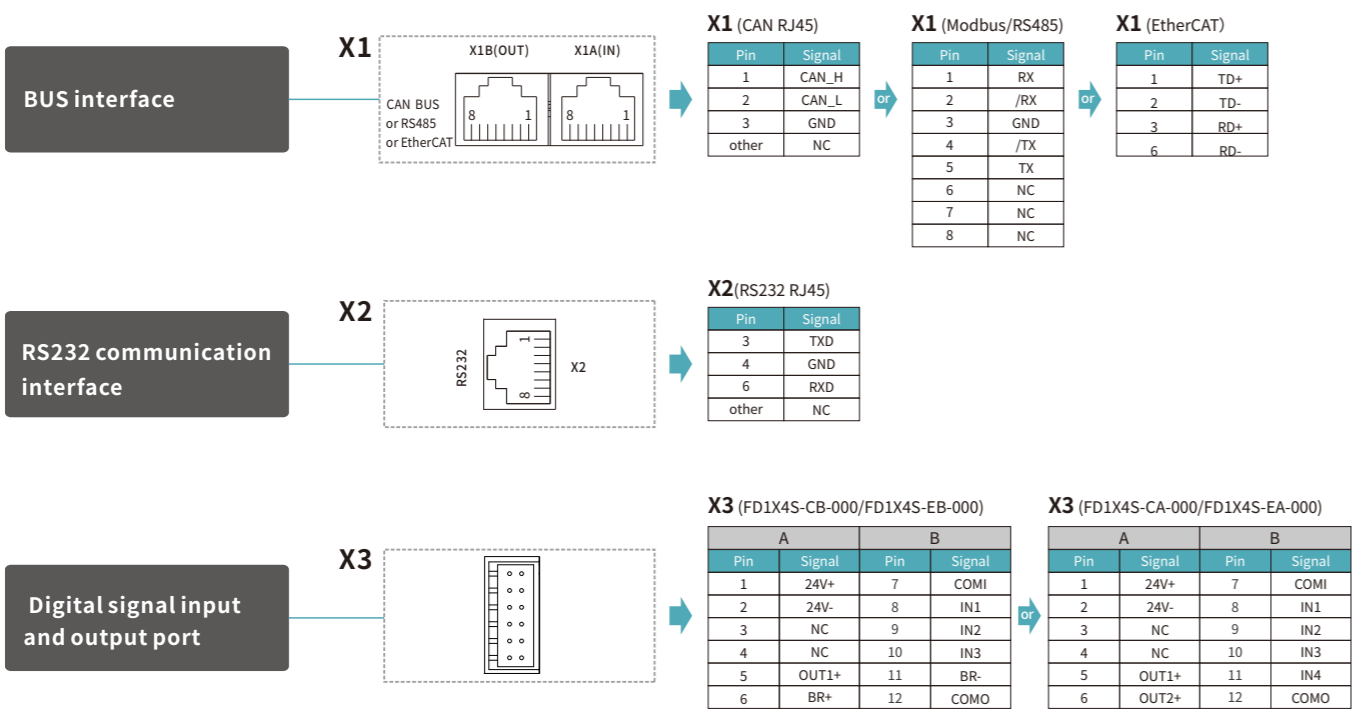

X3	PUL+, PUL-, DIR+, DIR-	Pulse signal input Input voltage :3.3V~24V Maximum frequency :500KHz
	24V+, 24V-	FD1X4S-C□-000&FD1X4S-E□-000 don't support Pulse control., Pin 1 and pin 2 of port X3 are multiplexed into 24V logic power input port.
	OUT1+, OUT2+, COMO	Digital signal output Max output current: 100mA
	IN1, IN2, IN3, IN4, COMI	Digital signal input High level: Input voltage 12.5VDC~30VDC, input current4~20mA Low level: 0VDC~5VDC Input frequency: <1KHz
BR+, BR-	FD114S-□B-000&FD124-□B-000, input current of brake port is 0.5A FD134S-□B-000, input current of brake port is 0.8A FD144S-□B-000, input current of brake port is 1A	

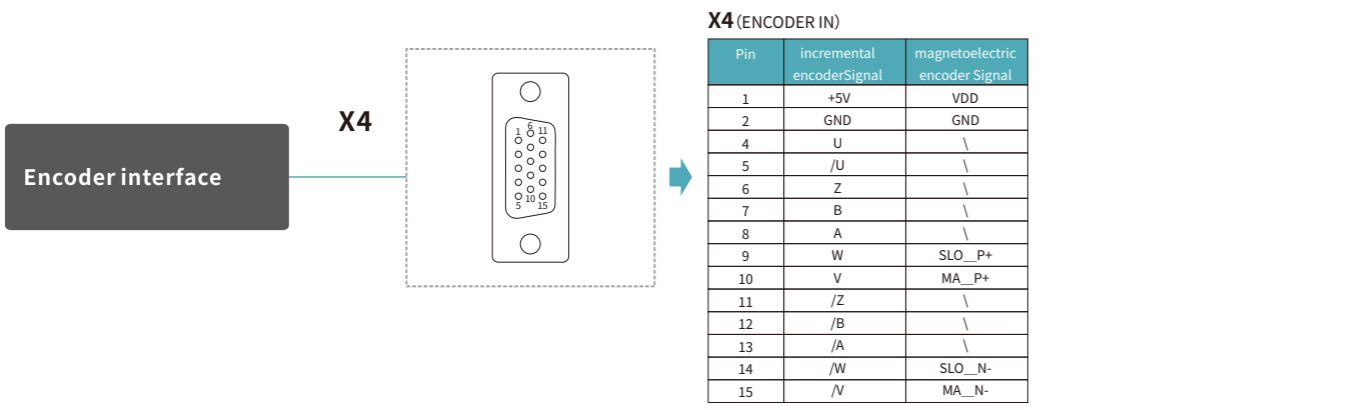
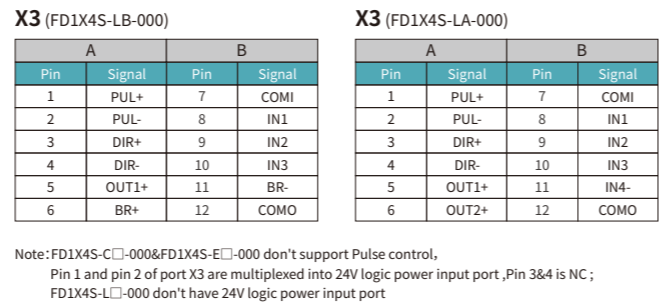

Wiring Diagram of X3 Port

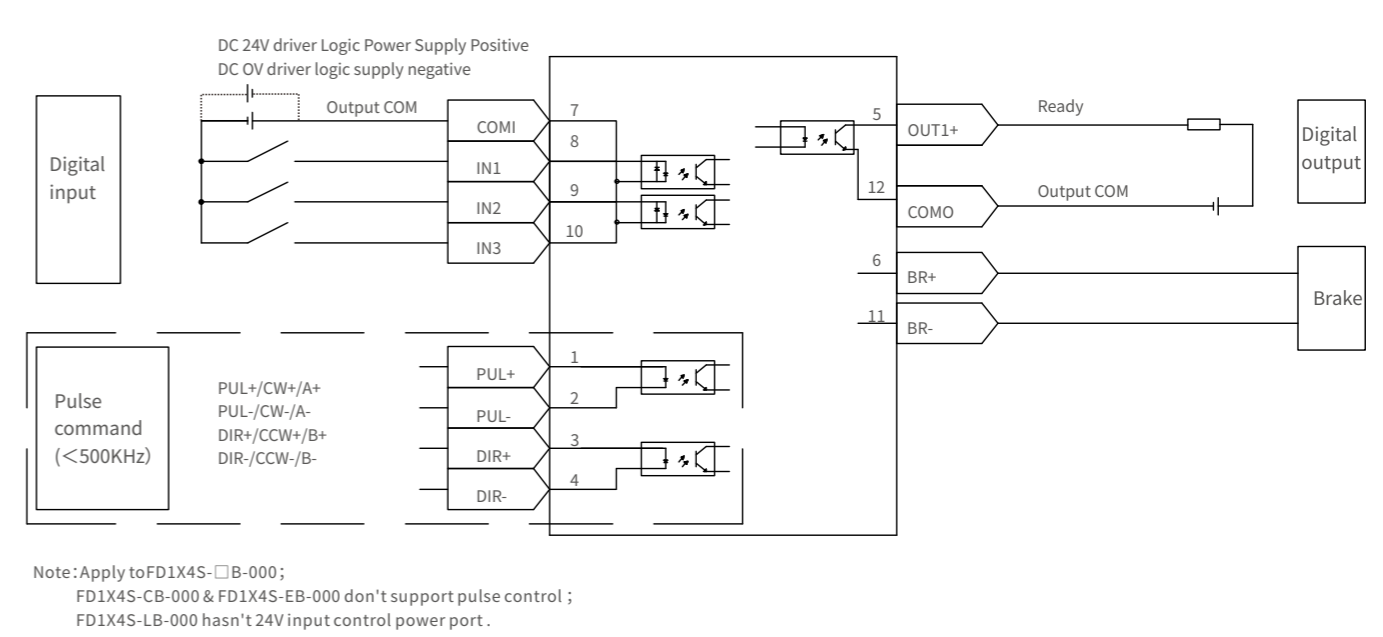
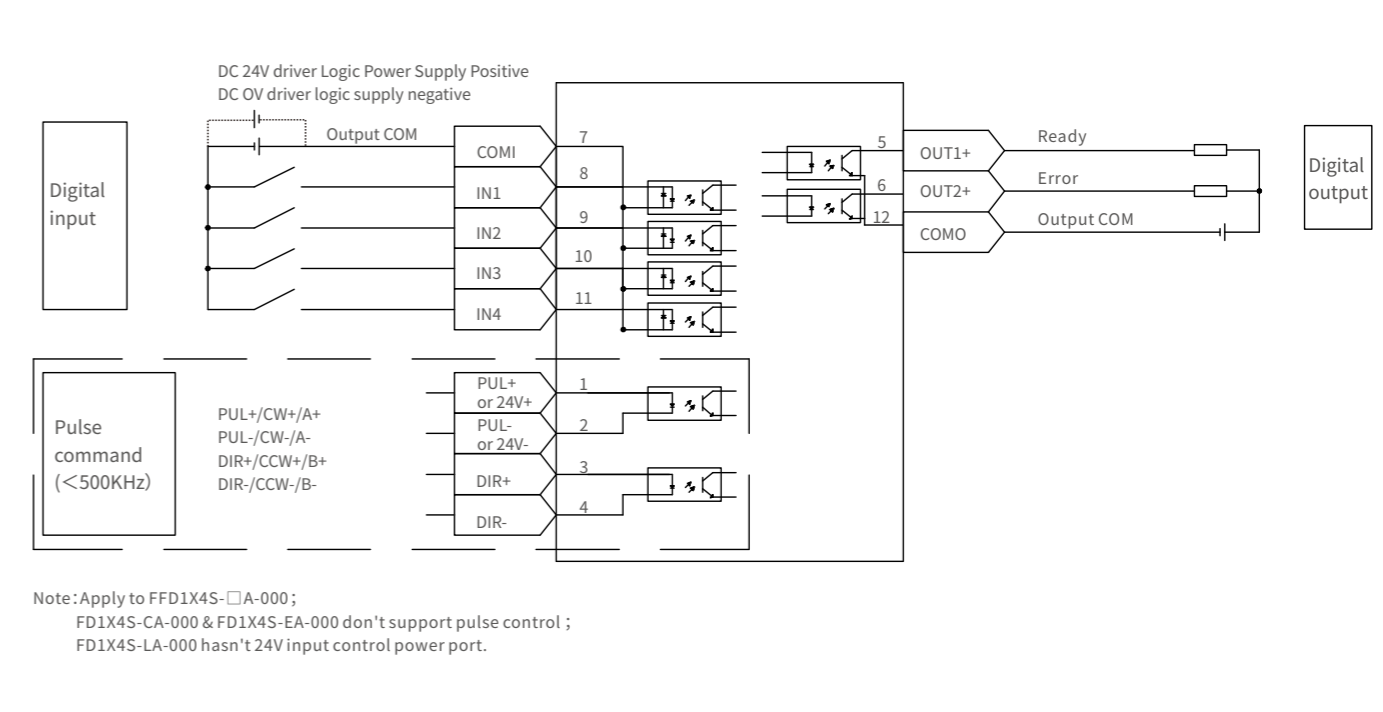

Mechanical Dimension Drawing (FD114S, FD124S)

(Unit: mm)

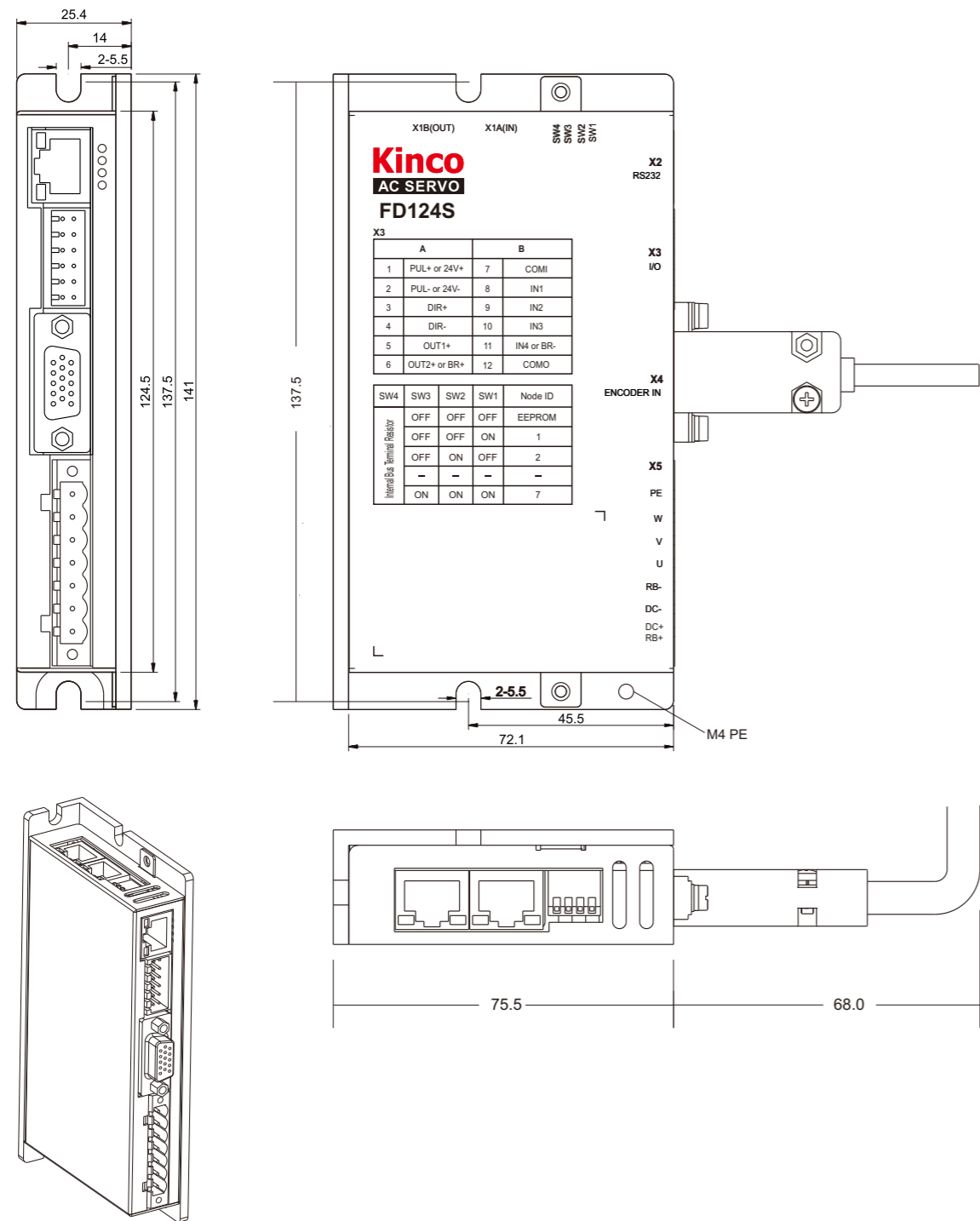

Mechanical Dimension Drawing (FD134S)

(Unit: mm)

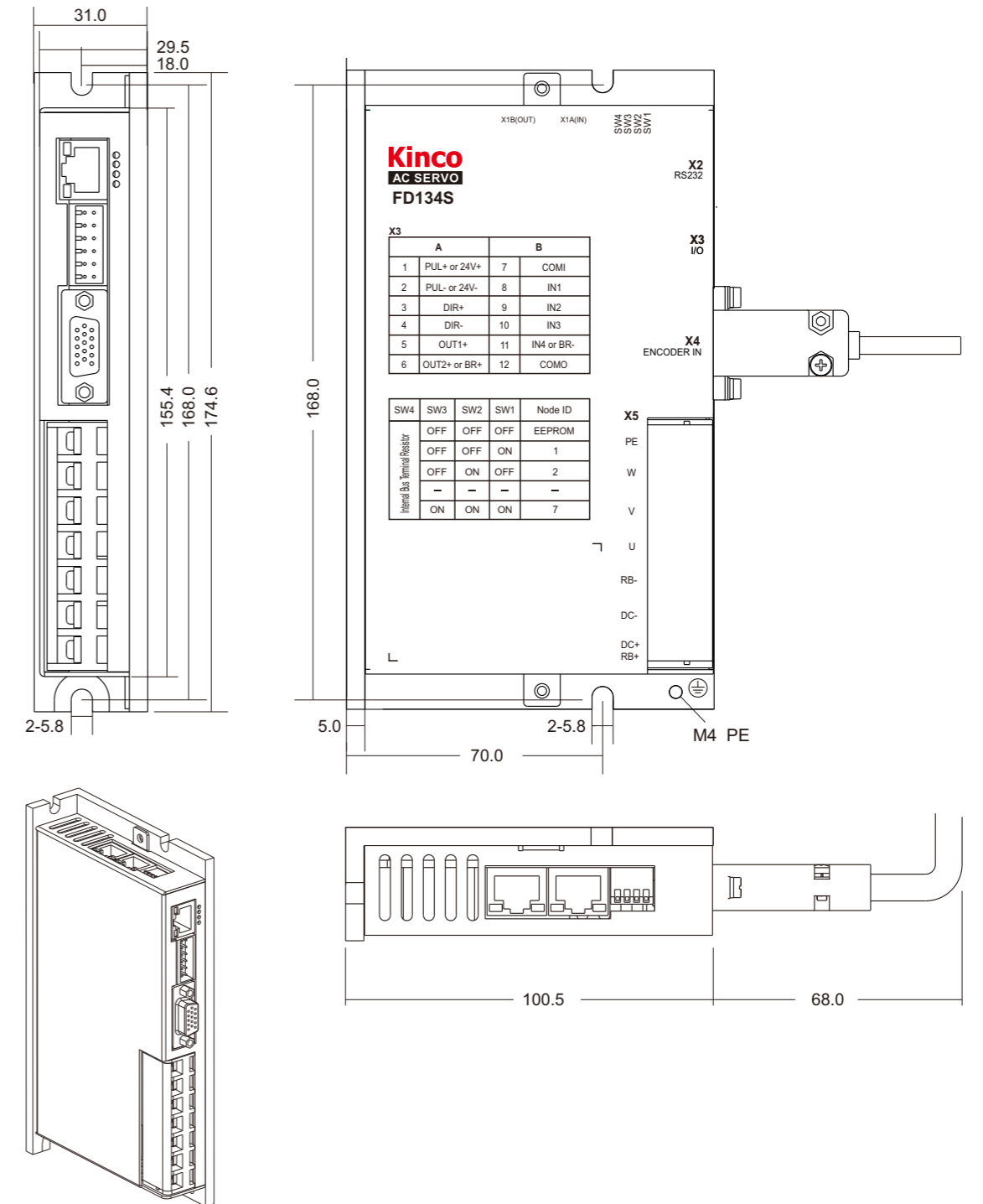

mechanical dimension drawing (FD144S)

(unit: mm)

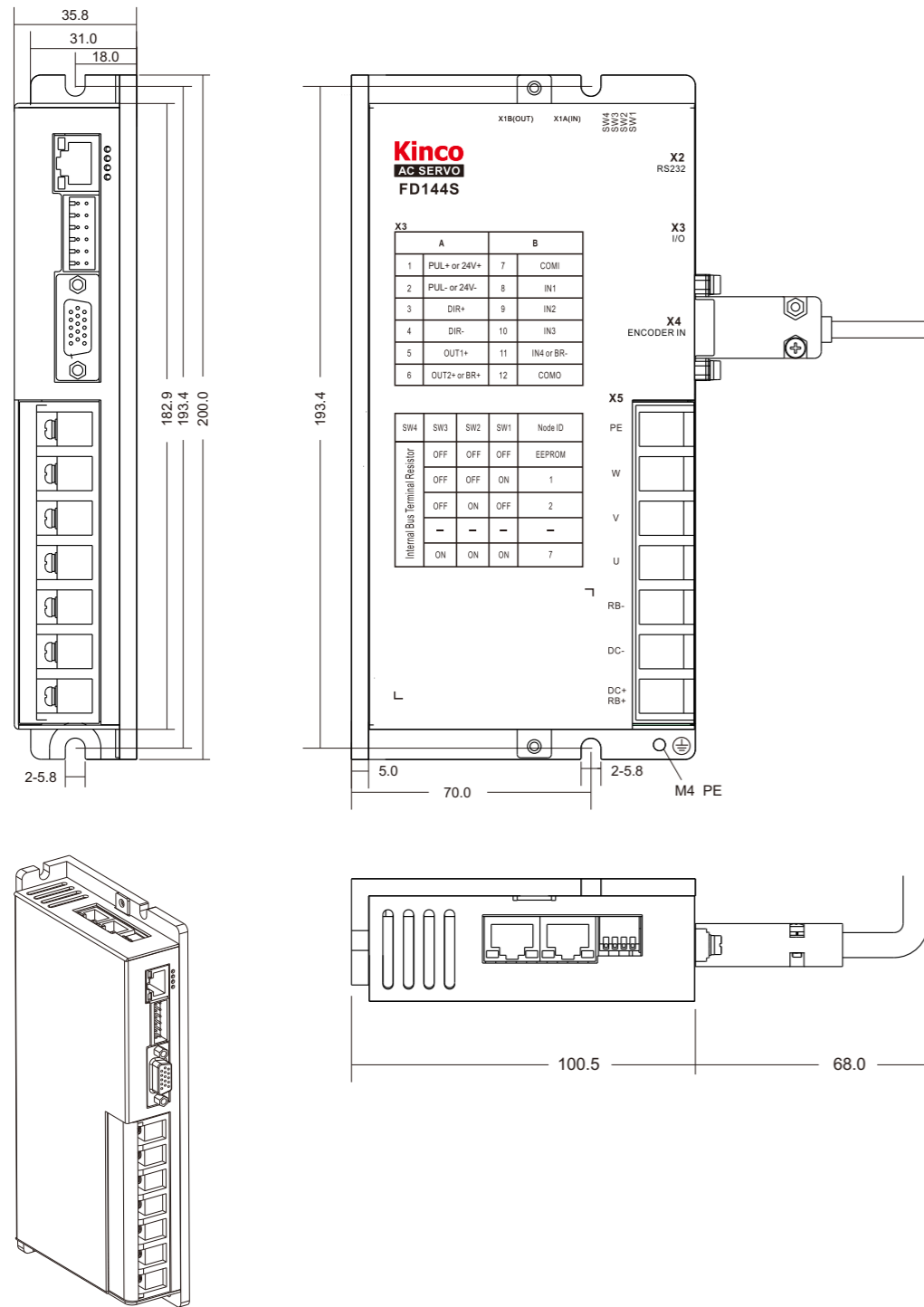

FD1X3 Technical Specifications Table

Model Parameter		FD123-□□-00■	FD133-□□-00■
Rated output voltage	main supply power	DC24V~70V	
	control circuit power	DC24V 1A (optional)	
Rated output current	Rated current (rms)	10A	20A
	Peak current (PEAK)	45A	50A
Feedback signal		2500PPR(Incremental difference 5V encoder)(available for FD1X3-□□-000); 16 bit multi-turn absolute encoder, 20 bit single-turn absolute encoder(available for FD1X3-□□-003)	
Brake chopper		Via wiring an external braking resistor (mainly in quick start and stop application)	
Brake chopper threshold		DC73V ± 2V (Default value, adjustable via software)	
Over-voltage alarming threshold		DC86V±2V	
Under-voltage alarming threshold		DC18V±2V	
Cooling method		Natural air cooling	
Weight (KG)		0.565	0.889
General unctions	Input specification	4 digital inputs, input current is 4~20mA, with COMI terminal for PNP(high level valid 12.5~30V) or NPN (low level valid 0~5V) connection	
	Input function	Define freely according to requirement, supporting following functions: Driver enable, driver fault reset, driver mode control, speed loop proportional control, positive limit, negative limit, homing signal, reverse command, internal speed section control, internal positive section control, quick stop, start homing, active command, switch electronic gear ratio, switch gain	
	Output specification	3 digital output :the output current of OUT1, OUT2 is 100 mA ;the output current of brake control output port(OUT5+/out5-) is 500 mA, can drive brake device directly.	
	Output function	Define freely according to requirement, supporting following functions: Driver ready, driver fault, position reached, motor zero speed, motor brake, motor speed reached, Z signal, maximum speed obtained in torque mode, motor brake, position limiting, reference found.	
	RS232	Default baudrate setting is 38400, the max. baudrate is 115.2KHz, use Kinco software to communicate with PC, or via free protocol to communicate with controller.	
	Protection function	Over-voltage protection, under-voltage protection, motor over-heat protection(I2T), short-circuit protection, drive over-heat protection, etc.	
RS485		The max. baudrate is 115.2KHz, use Modbus RTU protocol to communicate with controller.	
CAN BUS		Support maximum 1MHz baudrate. Communicate with controller via CANopen protocol	
EtherCAT		Support CoE(CiA402 protocol) and CSP/CSV/PP/PV/PT/HM mode, Communication speed 100M.	
Operation Environment	Operation temperature	0~40°C	
	Storage temperature	-10~70°C	
	Humidity(non-condensing)	Below 90%RH	
	Protection class	IP20	
	Installation environment	Installed in a dust-free, dry and lockable environment (such as in a electrical cabinet)	
	Installation mode	Vertical installation	
Height		Rated working altitude at 1000m or below, Above 1000m: Dcreasing 1.5% per 100m rise, maximum altitude 4000m	
Atmospheric pressure		86kpa~106kpa	

注: □□=LA: Communication port RS232、RS485
□□=CA: Communication port RS232、CANopen
□□=EA: Communication port RS232、EtherCAT

00■=003: Match communication encoder of SMS motor;

Interface Description (FD123)

X1
Bus communication interface
The following buses are held according to the model:
-Can bus
-Modbus/RS485 bus
-EtherCAT bus

DIP switch
Set communication ID and terminal resistor for CAN bus

X5
DC+, DC- :DC power supply input (24V~70V)
U, V, W, PE : Motor power connector
RB+, RB- : External brake resistor

X2
RS232 port

Display
4-dipit LED indicate the status or error information

X3
COM1, DIN1.....DIN4:
4-way Digital input Definable
OUT1, OUT2:
2-way Digital output Definable
PUL+: Pulse+/CW+/A+
PUL-: Pulse-/CW-/A-
DIR+: direction +/CCW+/B+
DIR-: direction -/CCW-/B-
24VS, GNDS: 24VDC power supply required when motor with brake
OUT5+, OUT5- :
Connect to motor brake

X4
Motor encoder input

Interface Description (FD133)

X1
Bus communication interface
The following buses are held according to the model:
-Can bus
-Modbus/RS485 bus
-EtherCAT bus

DIP switch
Set communication ID and terminal resistor for CAN bus

X5
DC+, DC- :DC power supply input (24V~70V)
U, V, W, PE : Motor power connector
RB+, RB- : External brake resistor

X2
RS232 port

Display
4-dipit LED indicate the status or error information

X3
COM1, DIN1.....DIN4:
4 Digital input terminals
OUT1, OUT2: 2 Digital output terminals
PUL+: Pulse+/CW+/A+
PUL-: Pulse-/CW-/A-
DIR+: direction +/CCW+/B+
DIR-: direction -/CCW-/B-
24VS, GNDS: 24VDC power supply required when motor with brake
OUT5+, OUT5- : Connect to motor brake

X4
Motor encoder input

FD1X3 port X4 description

BUS interface

X1

Pin	Signal
1	CAN_H
2	CAN_L
3	GND
other	NC

or

Pin	Signal
1	RX
2	/RX
3	GND
4	/TX
5	TX
6	NC
7	NC
8	GND

EtherCAT

Pin	Signal
1	TD+
2	TD-
3	RD+
6	RD-

RS232 communication interface

X2

Pin	Signal
3	TXD
4	GND
6	RXD
other	NC

Digital signal input and output port

X3

Pin	Signal	Pin	Signal
1	+24V	9	COM1
2	GNDS	10	DIN1
3	PUL+(AIN1)	11	DIN2
4	PUL-(GA)	12	DIN3
5	DIR+(AIN2)	13	DIN4
6	DIR-(GA)	14	OUT1+
7	OUT5+	15	OUT2+
8	OUT5-	16	COMO

Encoder interface

X4

Pin	Signal	Pin	incremental encoder Signal	magnetolectric encoder Signal
1	+5V	1	+5V	+5V
2	A	2	A	
3	B	3	B	
4	Z	4	Z	
5	U	5	U	
6	V	6	V	
7	W	7	W	SD
8	PTC_IN	8	PTC_IN	
9	GND	9	GND	GND
10	/A	10	/A	
11	/B	11	/B	
12	/Z	12	/Z	
13	/U	13	/U	
14	/V	14	/V	
15	/W	15	/W	/SD

Wiring Diagram of terminal I/O X3 (FD123, FD133)

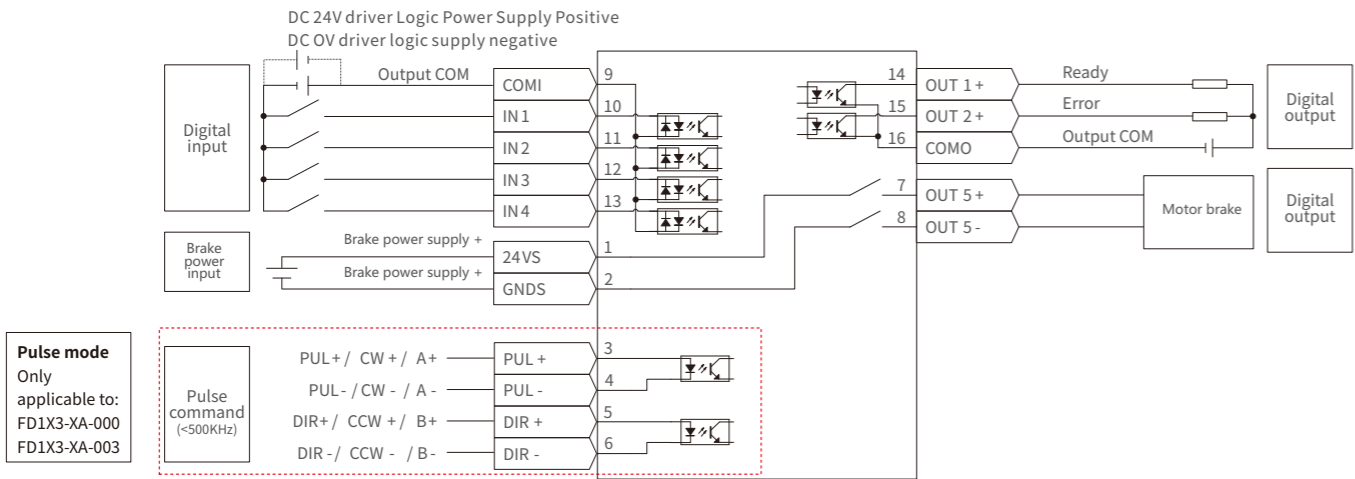

mechanical dimension drawing (FD123) (Unit: mm)

Note: Wiring is required around the driver. It is recommended to reserve more than 60mm of space.

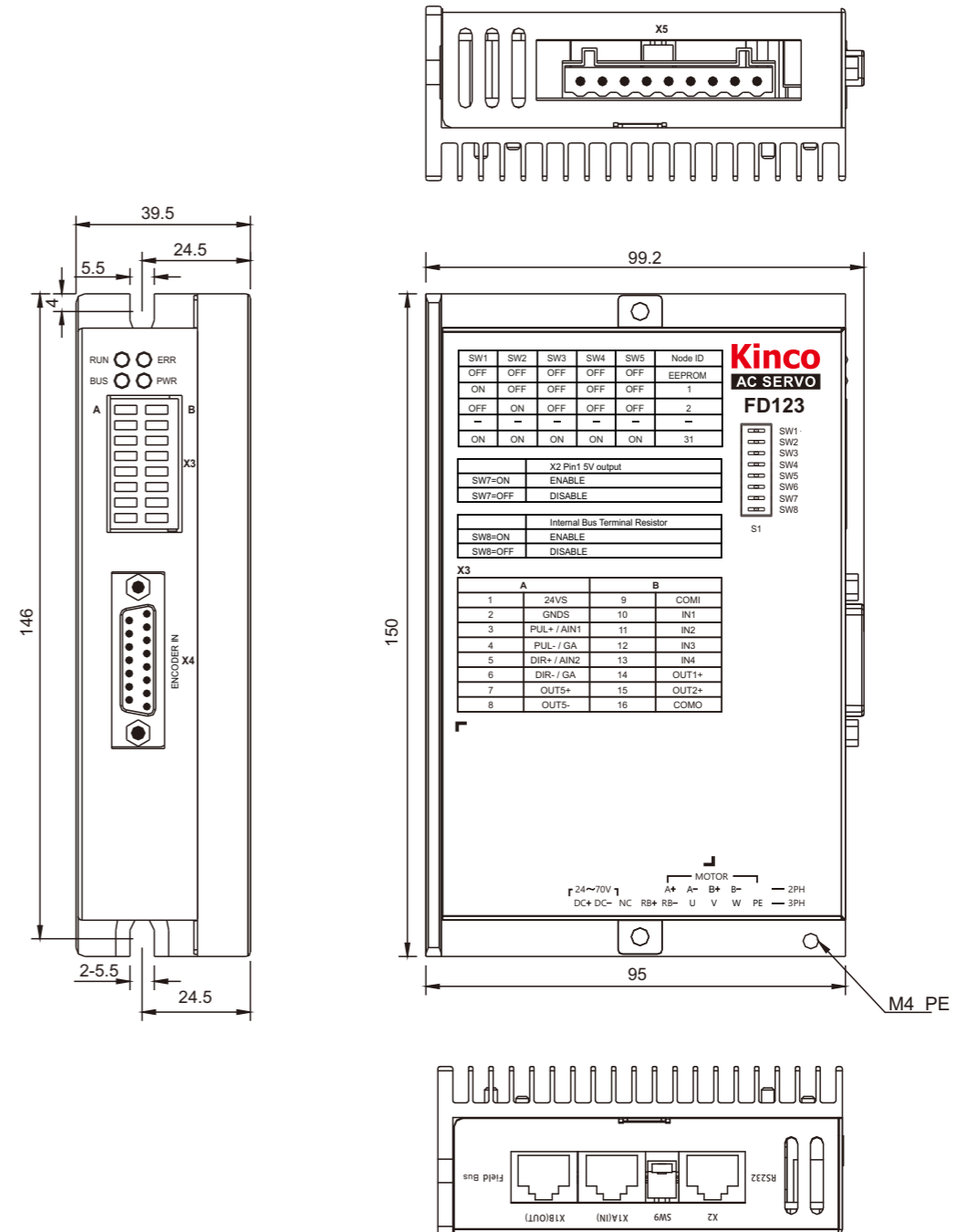

mechanical dimension drawing (FD133)

(Unit : mm)

Note: Wiring is required around the driver. It is recommended to reserve more than 60mm of space.

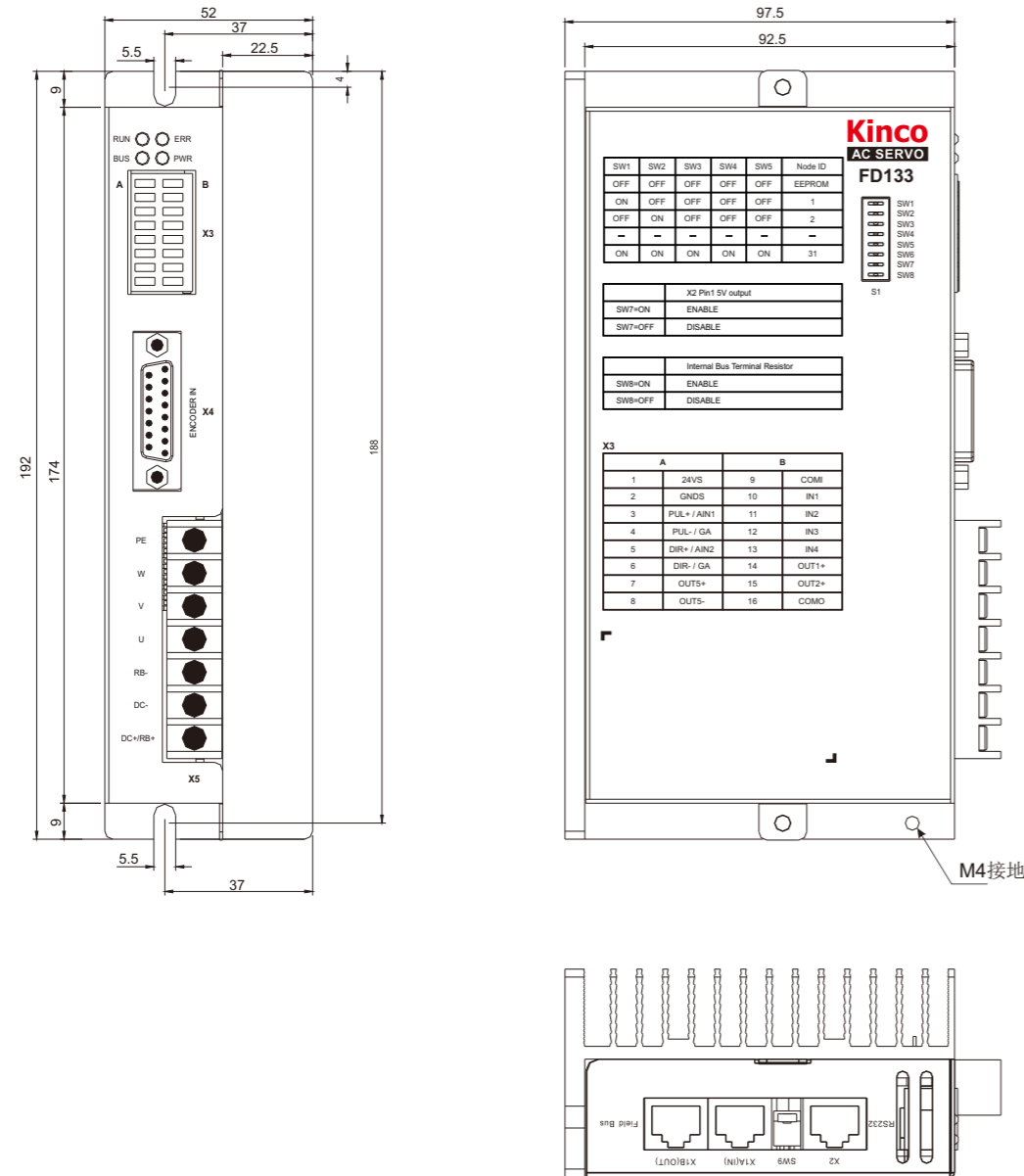

Technical Specifications of SMC Servo Motor (Magnetolectric encoder)

Motor series	SMC40S-0005-30M □K-5DSU	SMC40S-0010-30M □K-5DSU	SMC60S-0020-30M □K-3DSU	SMC60S-0040-30M □K-3DSU	SMC80S-0075-30M □K-3DSU	
DC link voltage VDC	48	48	48	48	48	
Continuous performance	Rated power Pn(W)	50	100	200	400	750
	Rated torque Tn(Nm)	0.16	0.32	0.64	1.27	2.39
	Rated speed nN(rpm)	3000	3000	3000	3000	3000
	Rated current In(A)	1.5	3.2	5.1	10.1	19
Maximum torque Tm(Nm)	0.48	0.96	1.92	3.81	7.17	
Maximum current Im(A)	4.5	9.6	15.3	30.3	57	
Standstill torque Ts(Nm)	0.176	0.352	0.7	1.4	2.63	
Standstill current Is(A)	1.65	3.52	5.6	11.1	20.9	
Resistance Line - Line RL(Ω)	4.1	1.5	0.889	0.329	0.11	
Inductance Line - Line LL(mH)	4.5	1.9	1.51	0.68	0.41	
Electrical time constant τe (ms)	1.1	1.27	1.7	2.07	3.73	
Mechanical time constant τm (ms)	1	0.67	1.92	1.33	1.19	
	1.17 (with brake)	0.94 (with brake)	1.92 (with brake)	1.33 (with brake)	1.198 (with brake)	
Reverse voltage constant Ke (V/krpm)	7	7	8	8	8	
Torque constant Kt (Nm/A)	0.11	0.11	0.132	0.132	0.132	
Rotor moment of inertia Jm (Kg · cm ²)	0.018	0.033	0.214	0.405	1.087	
	0.021 (with brake)	0.046 (with brake)	0.218 (with brake)	0.409 (with brake)	1.099 (with brake)	
Brake holding torque T(Nm)	0.32	0.32	1.5	1.5	3.2	
Pole pair number	5	5	3	3	3	
Maximum voltage rising du/dt (KV/μs)	8	8	8	8	8	
Insulation class	F	F	F	F	F	
Maximum radial force F(N)	120	120	180	180	335	
Maximum axial force F(N)	60	60	90	90	167.5	
Weight G(Kg)	0.4	0.57	1.2	1.6	2.8	
	0.6 (with brake)	0.77 (with brake)	1.6 (with brake)	2.1 (with brake)	3.4 (with brake)	
Length of motor L(mm)	74.6±1	96.6±1	91±1.5	117±1.5	128.5±1.5	
	104.6±1.5 (with brake)	126.6±1 (with brake)	121±1.5 (with brake)	147±1.5 (with brake)	158±1.5 (with brake)	
Position feedback device	16 bit single-turn magnetolectric encoder					
Cooling method	Totally enclosed, non - ventilated"					
Protection level	IP65, shaft sealing IP54					
Environment conditions for operation	Temperature	- 20~40°C (non-freezing)				
	Humidity	Below 90 % RH (no condensation)				
	Ambient environment	Away from active gas,combustible gas,oil drops and dust				
	Altitude	Maximum altitude 4000 m, rated power at 1000 m or below. Above 1000m, decreasing 1.5 % per every 100m rise				

40 flange magnetolectric encoder motor

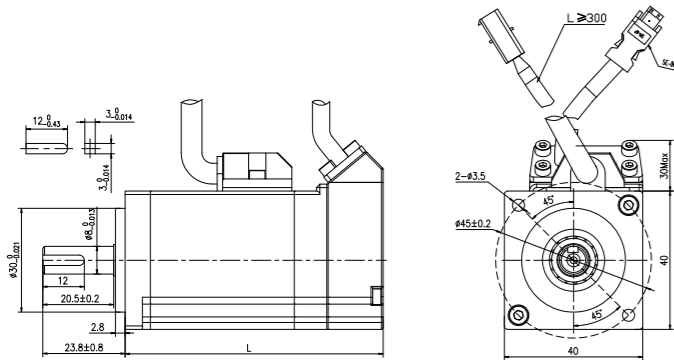

40 flange magnetolectric encoder motor (with brake)

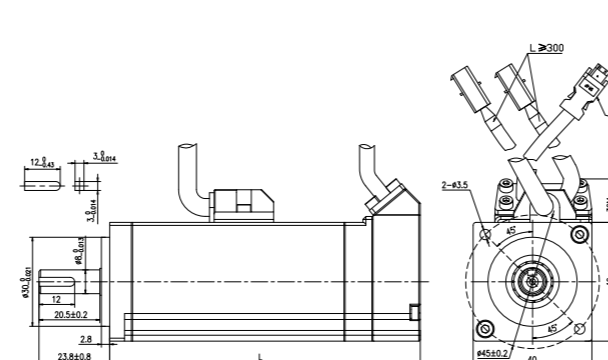

Motor torqur curve

(Not show the curve under three times overload ability)

SMC40S-0005-30M□K-5DSU 50W

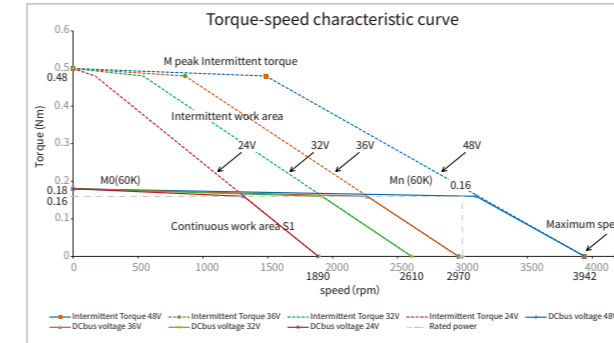

SMC40S-0010-30M□K-5DSU 100W

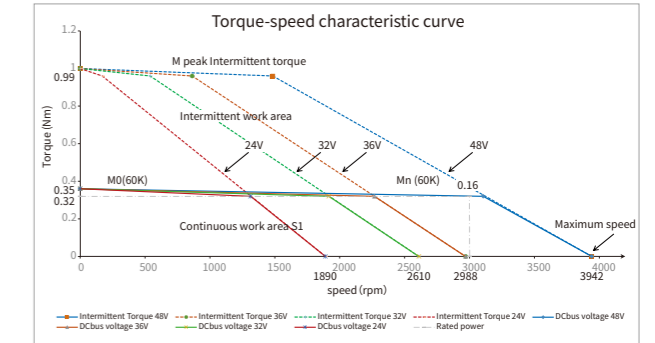

60 flange magnetolectric encoder motor

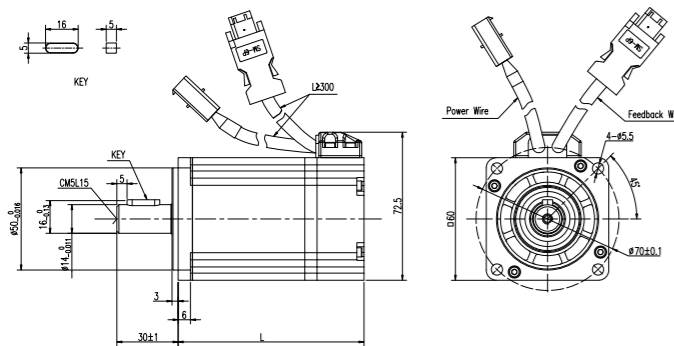

60 flange magnetolectric encoder motor (with brake)

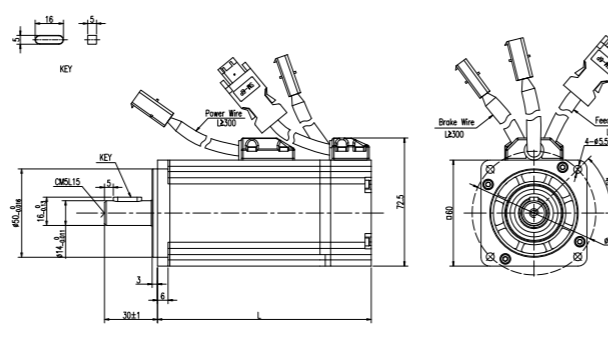

SMC60S-0020-30M□K-3DSU 200W

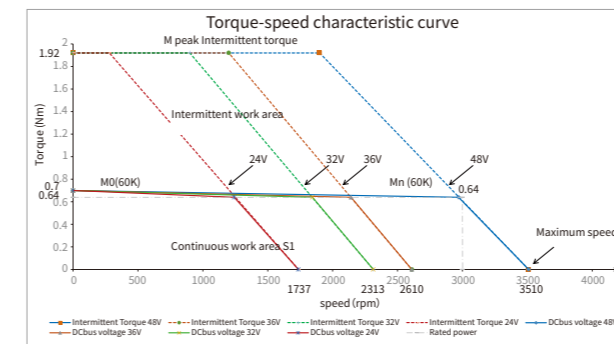

SMC60S-0040-30M□K-3DSU 400W

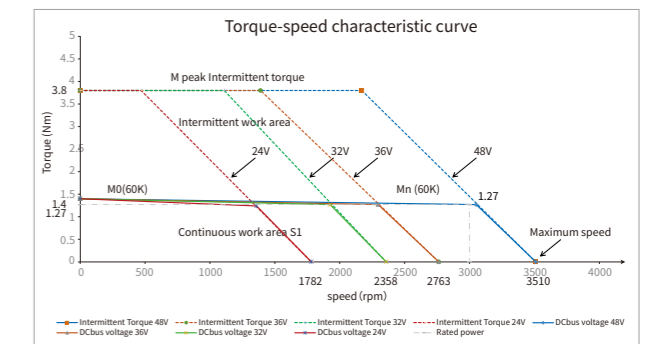

80 flange magnetolectric encoder motor

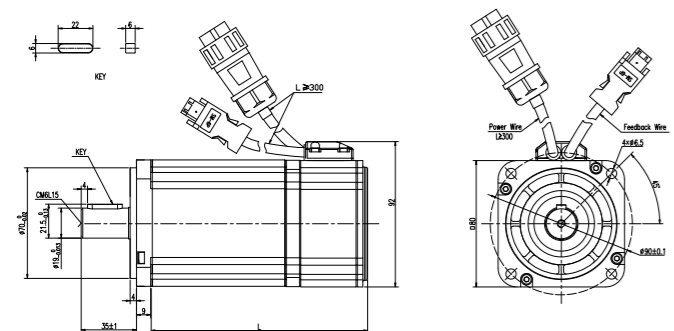

80 flange magnetolectric encoder motor (with brake)

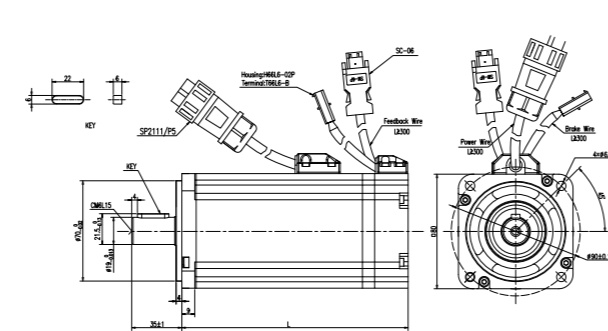

SMC80S-0075-30M□K-3DSU 750W

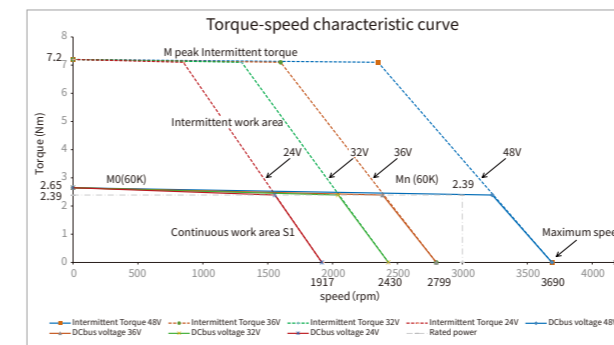

Technical Specifications of SMC Servo Motor

Motor series	SMC60S-0020-30A□K-3DSH	SMC60S-0040-30A□K-3DSH	SMC80S-0075-30A□K-3DSH	SMC130D-0120-30A□K-4DKR	SMC130D-0150-30A□K-4DKR	
DC link voltage VDC	48	48	48	48	48	
Continuous performance	Rated power Pn(W)	200	400	750	1200	1500
	Rated torque Tn(Nm)	0.64	1.27	2.39	3.8	5
	Rated speed nN(rpm)	3000	3000	3000	3000	3000
	Rated current In(A)	5.1	10.1	19	31.6	37.5
Maximum torque Tm(Nm)	1.92	3.81	7.17	9.5	12.5	
Maximum current Im(A)	15.3	30.3	57	79	93.4	
Standstill torque Ts(Nm)	0.7	1.4	2.63	4.18	5.5	
Standstill current Is(A)	5.6	11.1	20.9	34.76	39.2	
Resistance Line - Line RL(Ω)	0.889	0.329	0.11	0.041	0.025	
Inductance Line - Line LL(mH)	1.51	0.68	0.41	0.279	0.169	
Electrical time constant τe (ms)	1.7	2.07	3.82	0.68	0.676	
Mechanical time constant τm (ms)	1.88	1.32	1.38	3	3	
	1.92 (with brake)	1.33 (with brake)	1.395 (with brake)	3 (with brake)	3 (with brake)	
Reverse voltage constant Ke (V/krpm)	8	8	8	8	7.98	
Torque constant Kt (Nm/A)	0.132	0.132	0.132	0.132	0.132	
Rotor moment of inertia Jm (Kg · cm ²)	0.214	0.405	1.26	7.4	12	
	0.218 (with brake)	0.409 (with brake)	1.272 (with brake)	7.5 (with brake)	12.1 (with brake)	
Brake holding torque T(Nm)	1.3	1.3	3.2	10	10	
Pole pair number	3	3	3	4	4	
Maximum voltage rising du/dt (KV/μs)	8	8	8	8	8	
Insulation class	F	F	F	F	F	
Maximum radial force F(N)	180	180	335	900	900	
Maximum axial force F(N)	90	90	167.5	450	450	
Weight G(Kg)	1.1	1.6	2.9	6.2	7.5	
	1.6 (with brake)	2.1 (with brake)	3.5 (with brake)	8.5 (with brake)	9.8 (with brake)	
Length of motor L(mm)	104 ± 1.5	130 ± 1.5	140 ± 1.5	147 ± 1.5	163 ± 1.5	
	150 ± 1.5 (with brake)	176 ± 1.5 (with brake)	187 ± 1.5 (with brake)	208 ± 1.5 (with brake)	224 ± 1.5 (with brake)	
Position feedback device	2500 PPR incremental encoder					
Cooling method	Totally enclosed, non - ventilated					
Protection level	IP65, shaft sealing IP54					
Environment conditions for operation	Temperature	- 20~40°C (non-freezing)				
	Humidity	Below 90 % RH (no condensation)				
	Ambient environment	Away from active gas, combustible gas, oil drops and dust				
	Altitude	Maximum altitude 4000 m, rated power at 1000 m or below. Above 1000m, decreasing 1.5 % per every 100m rise				

note: □=A — without brake
 □=B — brake

60 flange lead-out incremental encoder motor

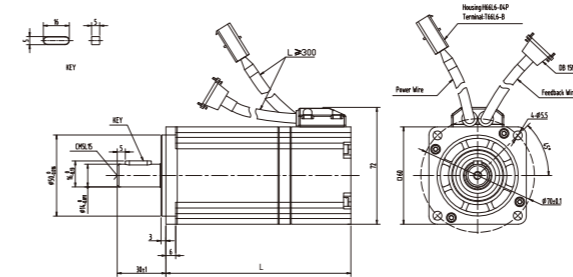

60 flange lead-out incremental encoder motor (with brake)

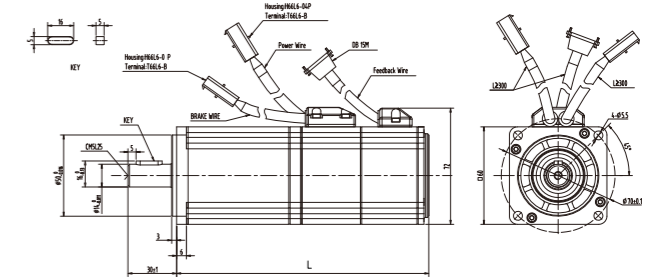

80 flange lead-out incremental encoder motor

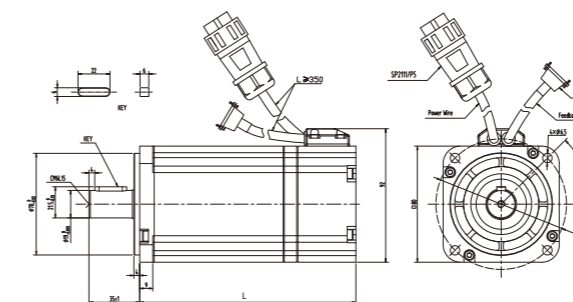

80 flange lead-out incremental encoder motor (with brake)

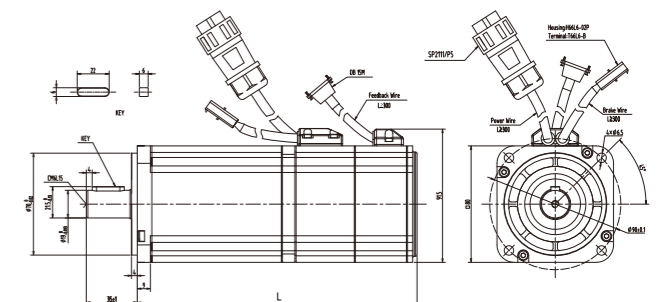

130 flange common aviation socket motor

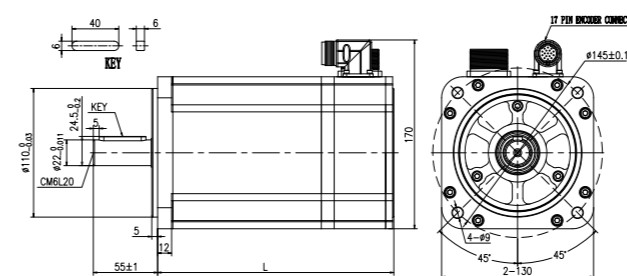

130 flange common aviation socket motor (with brake)

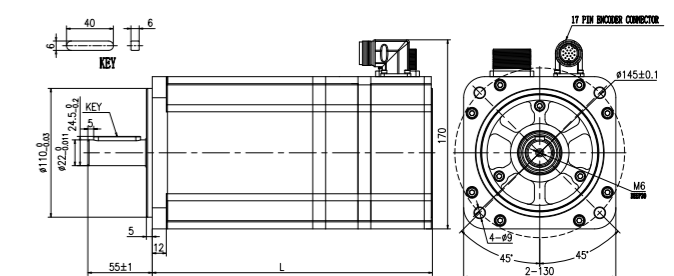

Motor torque curve

(Not show the curve under three times overload ability)

SMC60S-0020-30A□K-3DSH 200W

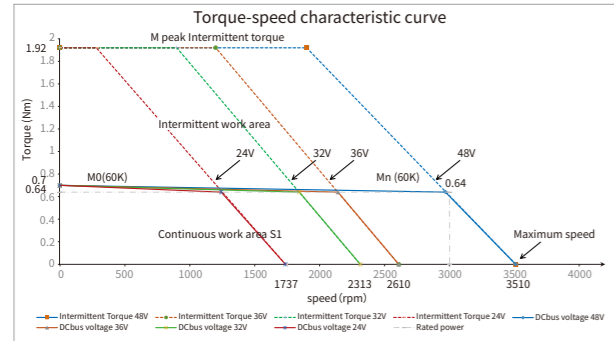

SMC60S-0040-30A□K-3DSH 400W

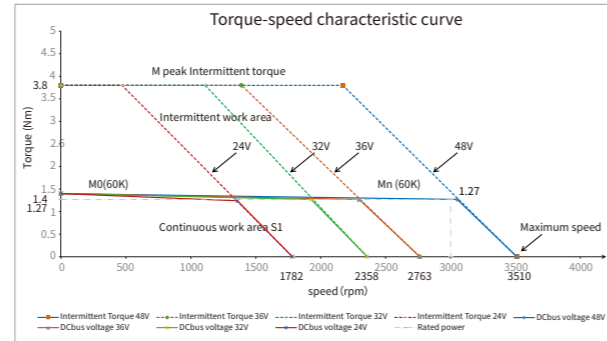

SMC80S-0075-30A□K-3DSH 750W

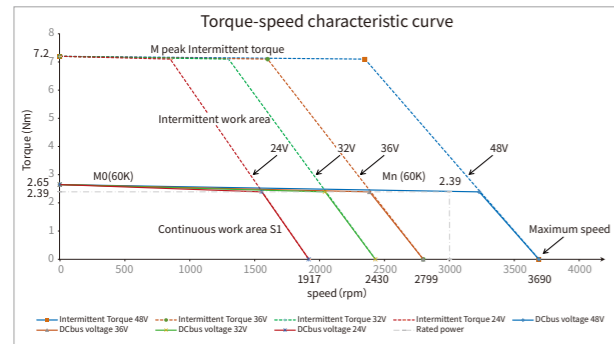

SMC130D-0120-30A□K-4DKR 1.2kW

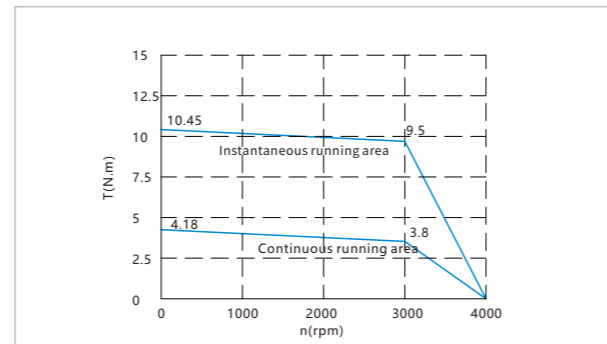

SMC130D-0150-30A□K-4DKR 1.5kW

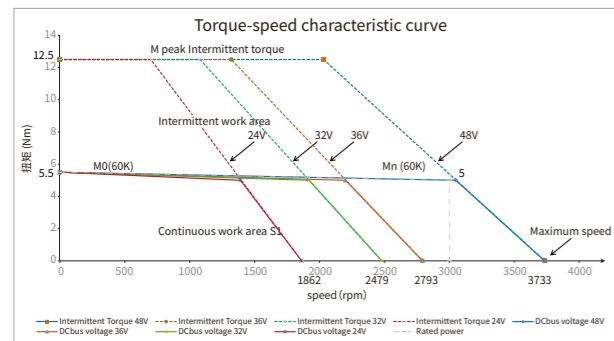

Technical Specifications of SMH Servo Motor

Motor series	SMH110D-0120-30A□K-4DKR	
DC link voltage VDC	48	
Continuous performance	Rated power PN(W)	1260
	Rated torque TN(N.m)	4
	Rated speed nN(rpm)	3000
	Rated current IN(A)	32
Maximum torque Tm (N.m)	12	
Maximum current Im (A)	96	
Standstill torque Ts(N.m)	4.4	
Standstill current Is (A)	35.2	
Resistance Line - Line RL (Ω)	0.035	
Inductance Line - Line LL (mH)	0.2	
Electrical time constant τe (ms)	5.7	
Mechanical time constant τm (ms)	2	
	2.1 (with brake)	
Reverse voltage constant Ke (V / krpm)	8	
Torque constant kt (N.m / A)	0.132	
Rotor moment of inertia Jm (Kg · cm ²)	5.8	
	6.1 (with brake)	
Brake holding torque T(Nm)	10	
Pole pair number	4	
Maximum voltage rising du / dt (kv / μs)	8	
Insulation class	F	
Maximum radial force Fr(N)	630	
Maximum axial force Fa(N)	315	
Weight G (Kg)	6.2	
	7.2 (with brake)	
Length of motor L (mm)	168 ± 1.5	
	228 ± 1.5 (with brake)	
Position feedback device	2500 PPR incremental encoder	
Cooling method	Totally enclosed, non - ventilated	
Protection level	IP65, shaft sealing IP54	
Environment conditions for operation	Temperature	- 20~40°C (non-freezing)
	Humidity	Below 90 % RH (no condensation)
	Ambient environment	Away from active gas,combustible gas,oil drops and dust
	Altitude	Maximum altitude 4000 m, rated power at 1000 m or below. Above 1000m, decreasing 1.5 % per every 100m rise"

Note □=A —without brake
 □=B —brake

110 flange common aviation socket motor

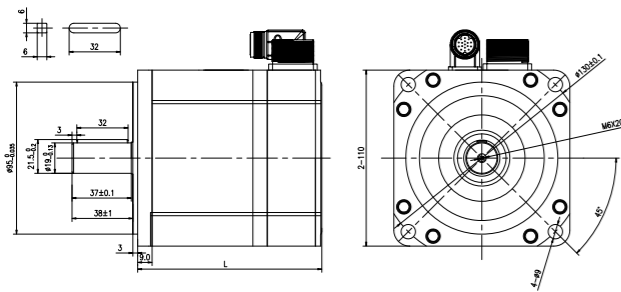

110 flange common aviation socket motor (with brake)

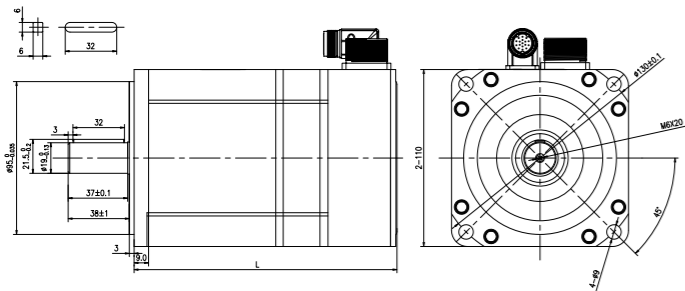

Motor torque curve

SMH110D-0120-30A□K-4DKR

1.2kW

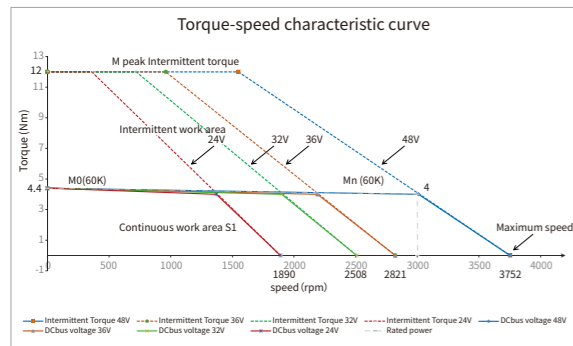

Technical Specifications of SMS Servo Motor

Motor series	SMS60S-0020-30K□K-3DSU	SMS60S-0040-30K□K-3DSU	SMS80S-0075-30K□K-3DSU	
DC link voltage VDC	48	48	48	
Continuous performance	Rated power PN(W)	200	400	750
	Rated torque TN(N.m)	0.64	1.27	2.39
	Rated speed nN(rpm)	3000	3000	3000
	Rated current IN(A)	5.1	10.1	19
Maximum torque Tm (N.m)	1.92	3.81	7.17	
Maximum current Im (A)	15.3	30.3	57	
Standstill torque Ts(N.m)	0.7	1.4	2.63	
Standstill current Is (A)	5.6	11.1	20.9	
Resistance Line - Line RL (Ω)	0.889	0.329	0.11	
Inductance Line - Line LL (mH)	1.51	0.68	0.41	
Electrical time constant τe (ms)	1.7	2.07	3.73	
Mechanical time constant τm (ms)	1.92	1.32	1.19	
	1.92 (with brake)	1.33 (with brake)	1.19 (with brake)	
Reverse voltage constant Ke (V / krpm)	8	8	8	
Torque constant kt (N.m / A)	0.132	0.132	0.132	
Rotor moment of inertia Jm (Kg · cm ²)	0.214	0.405	1.087	
	0.218 (with brake)	0.409 (with brake)	1.099 (with brake)	
Brake holding torque T(Nm)	1.5	1.5	3.2	
Pole pair number	3	3	3	
Maximum voltage rising du / dt (kv / μs)	8	8	8	
Insulation class	F	F	F	
Maximum radial force Fr(N)	180	180	335	
Maximum axial force Fa(N)	90	90	167.5	
Weight G (Kg)	1.2	1.6	2.8	
	1.5 (with brake)	2.1 (with brake)	3.4 (with brake)	
Length of motor L (mm)	91±1.5	117±1.5	128.5±1.5	
	121±1.5 (with brake)	147±1.5 (with brake)	158±1.5 (with brake)	
Position feedback device	16 bit multi-turn absolute encoder			
Cooling method	Totally enclosed, non - ventilated			
Protection level	IP65, shaft sealing IP54			
Environment conditions for operation	Temperature	- 20~40°C (non-freezing)		
	Humidity	Below 90 % RH (no condensation)		
	Ambient environment	Away from active gas,combustible gas,oil drops and dust		
	Altitude	Maximum altitude 4000 m, rated power at 1000 m or below. Above 1000m, decreasing 1.5 % per every 100m rise		

note: □=A —without brake
□=B —brake

60 flange low-voltage motor of SMC series

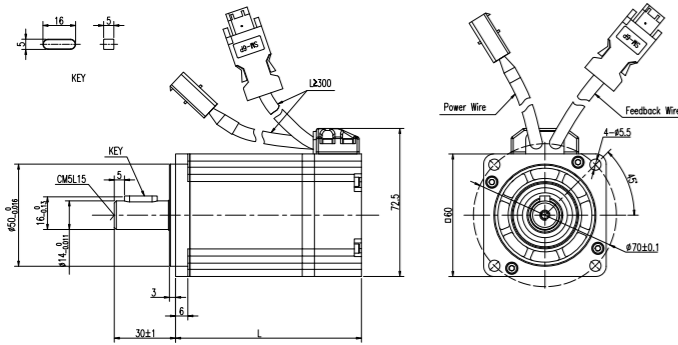

60 flange low-voltage motor of SMC series (with brake)

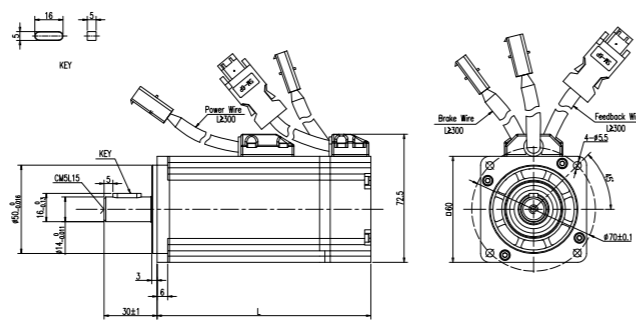

Motor torque curve

(Not show the curve under three times overload ability)

SMS60S-0020-30K□K-3DSU 200W

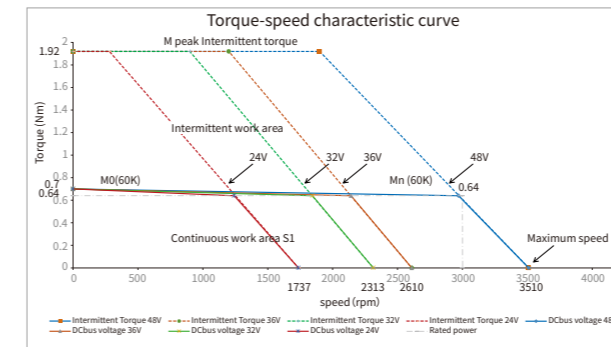

SMS60S-0040-30K□K-3DSU 400W

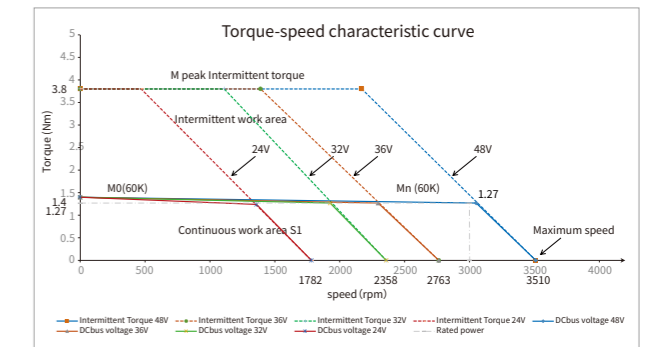

80 flange low-voltage motor of SMC series

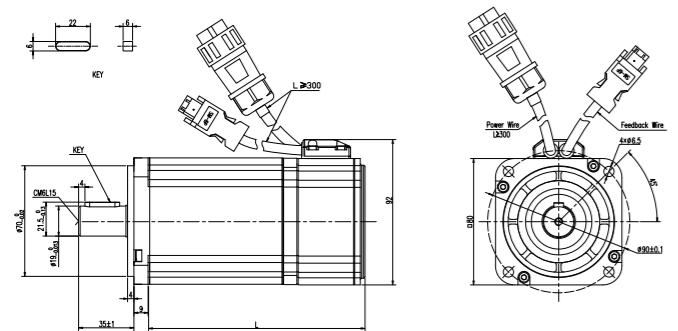

80 flange low-voltage motor of SMC series (with brake)

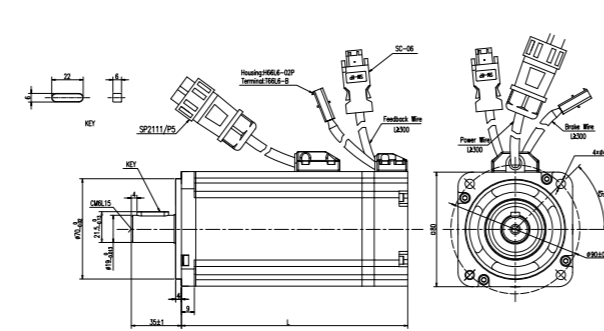

SMS80S-0075-30K□K-3DSU 750W

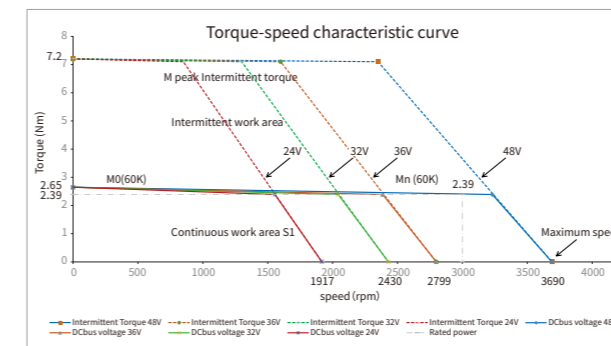

Cable(Encoder cable)

ENCCG-LL-GU

Wire spec:UL2661 1PX20AWG+2PX24AWG
20AWG cross sectional area 0.5189mm²
24AWG cross sectional area 0.2047mm²

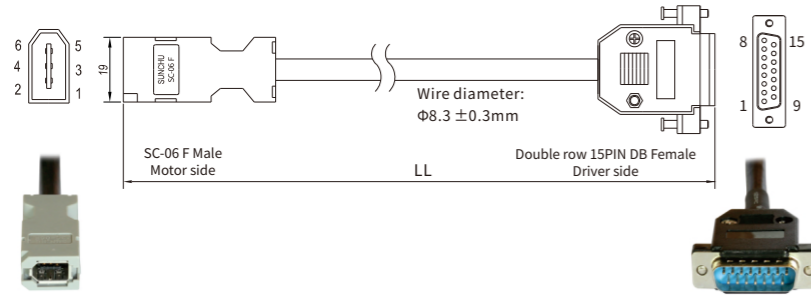

SC-06F	Color	Signal 1	Signal 2	DB15 Female
PIN1	Red	VDD	VDD	PIN1
PIN2	Black	GND	GND	PIN9
PIN3	Brown	MA_P+	\	PIN6
PIN4	Blue	MA_N-	\	PIN14
PIN5	Yellow	SLO_P+	SD	PIN7
PIN6	Green	SLO_N-	/SD	PIN15
Shell	Shielded wire	Shielding	Shielding	Shell

Corresponding accessory:ENCCG-GU

ENCHG-LL-GU

Wire spec:UL2661 1P*20AWG(26/0.16T)+2P*24AWG(11/0.16T)
24AWG cross sectional area 0.5189mm²
28AWG cross sectional area 0.2047mm²

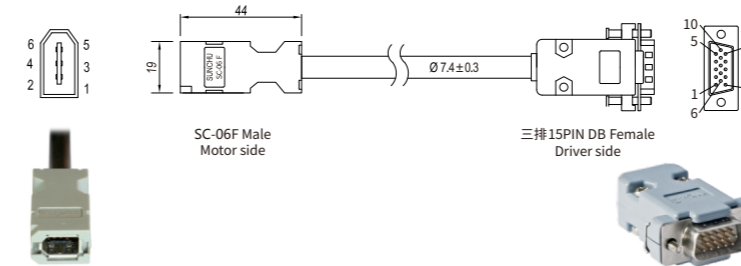

SC-06F	Color	Signal 1	Signal 2	DB 15 Female
PIN1	Red	VDD	VDD	PIN1
PIN2	Black	GND	GND	PIN2
PIN3	Brown	MA_P+	\	PIN10
PIN4	Blue	MA_N-	\	PIN15
PIN5	Yellow	SLO_P+	SD	PIN9
PIN6	Green	SLO_N-	/SD	PIN14
Shell	Shielded wire	Shielding	Shielding	Shell

Corresponding accessory:ENCHG-GU

ENCCG-(4)-GU-BT

Wire spec:3×2×0.2mm²

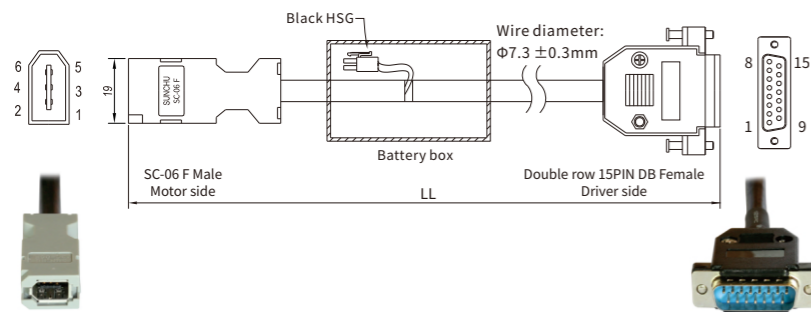

SC-06F	Color	black HSG	External single wire	Signal	DB15 Female
PIN1	Red			+5V	PIN1
PIN2	Black			GND	PIN9
PIN3	Brown	PIN1	Red	BAT+	
PIN4	Blue	PIN2	Black	BAT-	
PIN5	Yellow			SD	PIN7
PIN6	Green			/SD	PIN15
Shell	Shielded wire			Shielding	Shell

ENCCA-LL-KH

Wire spec:1P×24AWG(7/0.20T)+7P×28AWG(7/0.127T)
24AWG cross sectional area 0.2047mm²
28AWG cross sectional area 0.0804mm²

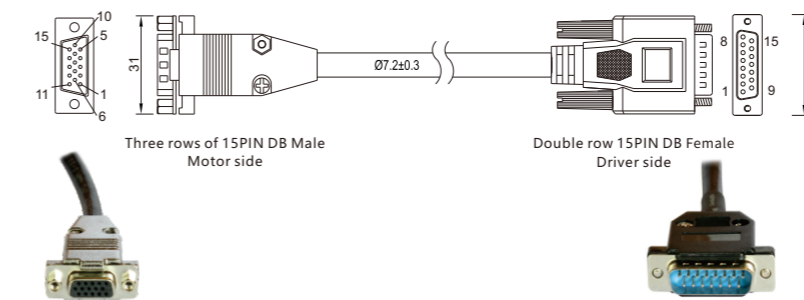

Three rows of 15PIN DB	Double row 15PIN DB	Signal	Color of external cable	Color of motor cable
PIN1	PIN1	+5V	Red (thick)	Red
PIN8	PIN2	A	Orange	Blue black
PIN7	PIN3	B	Yellow	Green
PIN6	PIN4	Z	Green	Yellow
PIN4	PIN5	U	Brown	Brown black
PIN10	PIN6	V	Purple	White black
PIN9	PIN7	W	Blue	Gray black
PIN2	PIN9	GND	Black (thick)	Black
PIN13	PIN10	/A	Orange white	Blue
PIN12	PIN11	/B	Yellow white	Green black
PIN11	PIN12	/Z	Green white	Yellow black
PIN5	PIN13	/U	Brown white	Brown
PIN15	PIN14	/V	Purple white	white
PIN14	PIN15	/W	Blue whitw	Gray
No PIN3	No PIN8			
Belonging ring	Db part	Shielding	Shielded wire	Shielded wire

Corresponding accessory:ENCCA-KH

ENCDG-LL-GU

Wire spec:UL2661 1PX20AWG+2PX24AWG
20AWG cross sectional area 0.5189mm²
24AWG cross sectional area 0.2047mm²

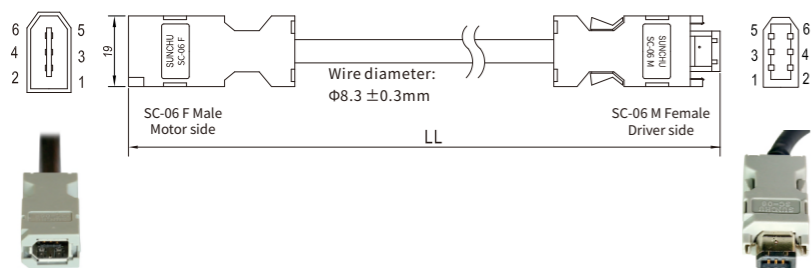

Color	SC-06	Signal 1	Signal 2
Red	PIN1	+5V	VDD
Black	PIN2	GND	GND
Brown	PIN3	BAT+	MA_P+
Blue	PIN4	BAT-	MA_N-
Yellow	PIN5	SD	SLO_P+
Green	PIN6	/SD	SLO_N-
Shielded wire	Shell	Shielding	Shielding

Corresponding accessory:ENCDG-GU

ENCHA-LL-KH

Wire spec:UL2464 24AWG/1P+28AWG/7P+AB 1061
24AWG cross sectional area 0.2047mm²
28AWG cross sectional area 0.0804mm²

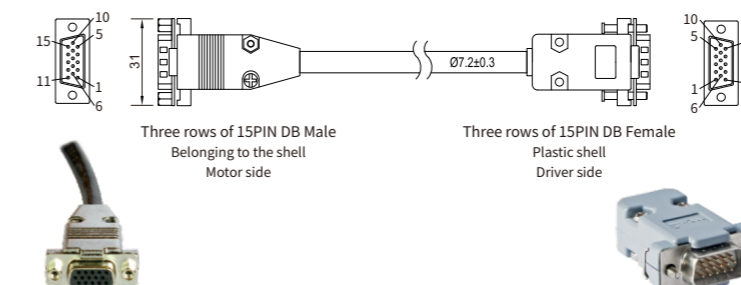

Three rows of 15PIN DB Male	Three rows of 15PIN DB Female	Signal	Color
PIN1	PIN1	+5V	Red (Thick)
PIN8	PIN8	A	Orange
PIN7	PIN7	B	Yellow
PIN6	PIN6	Z	Green
PIN4	PIN4	U	Brown
PIN10	PIN10	V	Purple
PIN9	PIN9	W	Blue
PIN2	PIN2	GND	Black (Thick)
PIN13	PIN13	/A	Orange white
PIN12	PIN12	/B	Yellow white
PIN11	PIN11	/Z	Green white
PIN5	PIN5	/U	Brown white
PIN15	PIN15	/V	Purple white
PIN14	PIN14	/W	Blue white
Shell	Shell	Shielding	Shielded wire

Corresponding accessory:ENCHA-KH

Cable(Encoder/Brake cable)

ENCHA-LL-KC0

Wire spec: UL2464 24AWG/1P+28AWG/7P+AB 1061
 24AWG cross sectional area 0.2047mm²
 28AWG cross sectional area 0.0804mm²

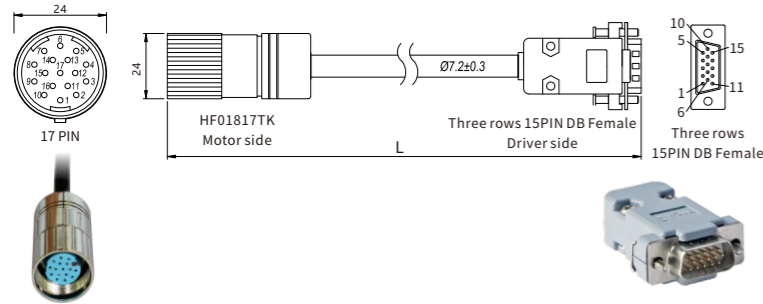

ENCHA-LL-KC0			
17PIN Air insertion	Three rows of 15PIN DB	Signal	Color
PIN1	PIN1	+5V	Red (thick)
PIN3	PIN8	A	Orange
PIN5	PIN7	B	Yellow
PIN14	PIN6	Z	Green
PIN9	PIN4	U	Brown
PIN11	PIN10	V	Purple
PIN16	PIN9	W	Blue
PIN2	PIN2	GND	Black (thick)
PIN4	PIN13	/A	Orange white
PIN6	PIN12	/B	Yellow white
PIN15	PIN11	/Z	Green white
PIN10	PIN5	/U	Brown white
PIN12	PIN15	/V	Purple white
PIN17	PIN14	/W	Blue white
Belonging ring	Belonging to the shell	Shielding	Shielded wire

Corresponding accessory: ENCHA-KC0

BRA-LL-KL

Wire spec: UL2464 2C×20AWG
 20AWG cross sectional area 0.5189mm²

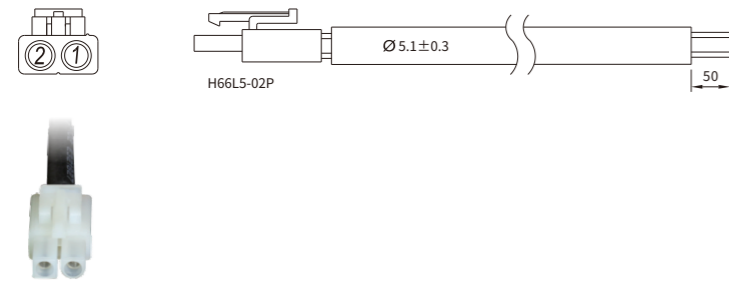

BRA-LL-KL		
Color	Signal	2PIN terminal
Red	brake +	PIN1
Blue	brake -	PIN2

Corresponding accessory: BRA-KL

Cable (Power cable)

MOT-005-LL-KL-D

Wire spec: 4×18AWG(41/0.167)
 18AWG cross sectional area 0.8107mm²

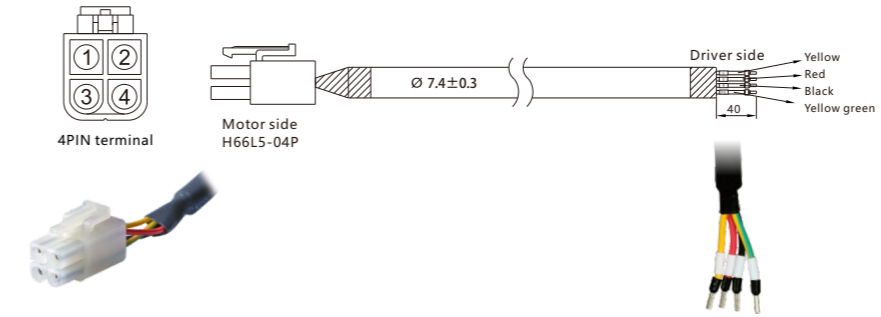

MOT-005-LL-KL-D		
Color	Signal	4PIN plug
Yellow	U	PIN1
Red	V	PIN2
Black	W	PIN3
Yellow green	PE	PIN4

Corresponding accessory: MOT-KL

MOT-008-LL-KL-D

Wire spec: UL2586 4×16AWG
 16AWG cross sectional area 1.318mm²

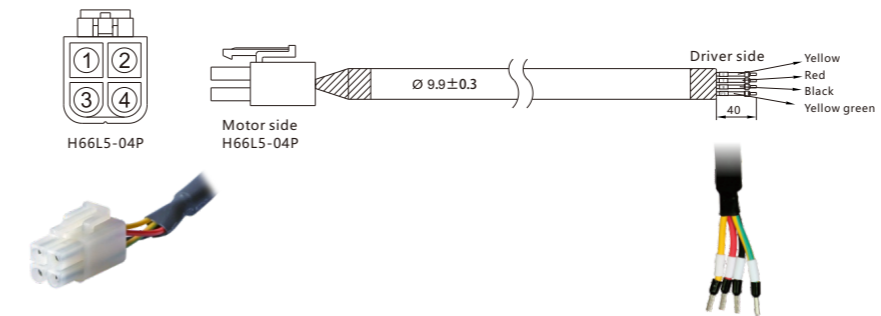

MOT-008-LL-KL-D		
Color	Signal	H66L5-04P
Yellow	U	PIN1
Red	V	PIN2
Black	W	PIN3
Yellow green	PE	PIN4

Corresponding accessory: MOT-KL

MOT-015-LL-KL-SP

Wire spec: UL2586 4×14AWG(50/0.25T)
 14AWG cross sectional area 2.075mm²

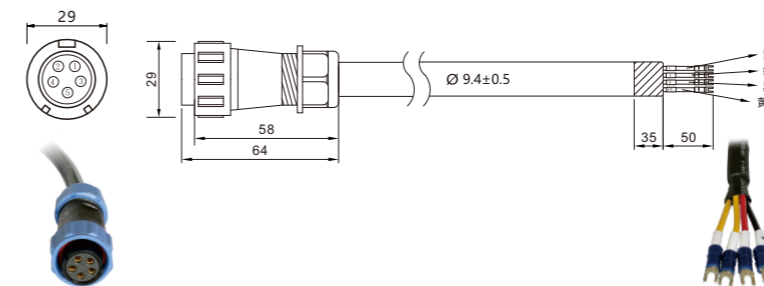

MOT-015-LL-KL-SP		
Color	Signal	5PIN Air insertion
Yellow	U	PIN1
Red	V	PIN2
Black	W	PIN3
Yellow green	PE+Shielding	PIN4
NC	NC	PIN5

Corresponding accessory: MOT-015-KL-SP

MOT-040-LL-KC5

Wire spec: :UL2517 3cx10AWG+3X19AGW
 10AWG cross sectional area 5.26mm²
 19AWG cross sectional area 0.5667mm²

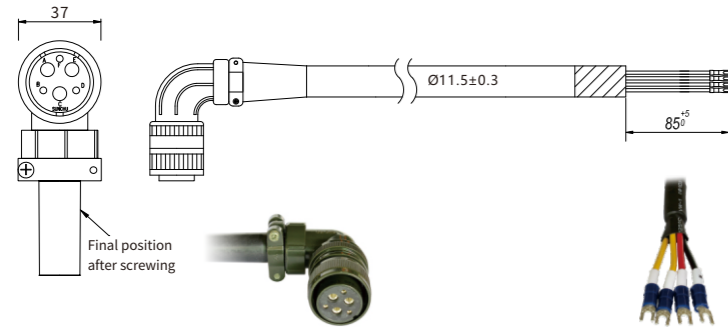

MOT-040-LL-KC5		
Color	Signal	Air insertion
Yellow	U	PINA
Red	V	PINE
Green	W	PINC
Yellow green	PE	PINF
Shielded wire	Shielding	Metal ring

Corresponding accessory bag: MOT-KC5-B

MOT-040-LL-KC5-B

Wire spec: :UL2517 3cx10AWG+3X19AGW
 10AWG cross sectional area 5.26mm²
 19AWG cross sectional area 0.5667mm²

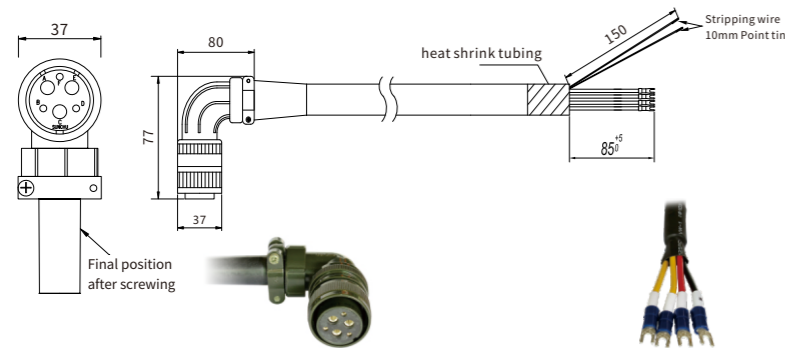

MOT-040-LL-KC5-B		
Color	Signal	Air insertion
Yellow	U	PINA
Red	V	PINE
Green	W	PINC
Yellow Green	PE	PINF
Red	Brake+	PINB
Blue	Brake-	PIND
Shielded wire	Shielding	Shell

Corresponding accessory bag: MOT-KC5-B

MD series integrated servo motor

Innovative and Practical Body Design



MD60 200W/400W

MD80 750W

Type description

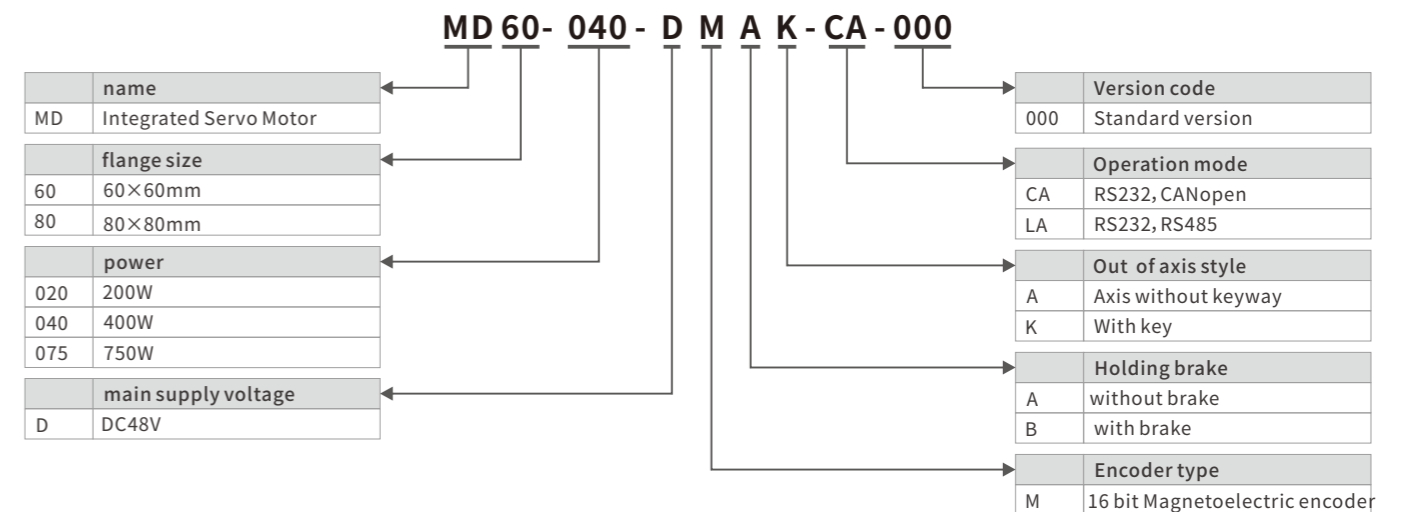

MD Technical Specifications Table

Integrated servo motor model		MD60-020-DMAK-□A-000	MD60-040-DMAK-□A-000	MD80-075-DMAK-□A-000
power	main supply power	DC24V~70V	DC24V~70V	DC24V~70V
	Rated current (RMS)	5A	10A	20A
current	Peak current (PEAK)	21A	36A	80A
	Feedback signal	16 bit Single-turn magnetoelectric encoder;		
Brake chopper	Via wiring an external braking resistor (mainly in quick start and stop application)			
Brake chopper threshold	DC73V ± 2V (Default value, Adjustable via software)			
Over-voltage alarming threshold	DC83V ± 2V			
Under-voltage alarming threshold	DC18V ± 2V			
Cooling method	Natural air cooling			
Input specification	COMI terminal for 4 digital inputs high level : 12.5VDC~30VDC Low level : 0VDC~5VDC Maximum frequency: 1KHz 2 High Speed Digital Inputs Input voltage: 3.3V~24V Maximum frequency: 500KHz			
Output specification	COMO terminal for 2 digital outputs Maximum output current: 100mA			
Pulse direction control	Pulse+direction, CCW+CW, phase A+ phase B (5V~24V) Input voltage: 3.3V~24V; Maximum frequency: 500KHz			
Brake	Built-in brake power supply 24V maximum current 0.5A	Built-in brake power supply 24V maximum current 0.5A	Built-in brake power supply 24V maximum current 1 A	
RS232	Default baudrate setting is 38400, the max. baudrate is 115.2KHz, use Kinco software to communicate with PC, or via free protocol to communicate with controller.			
RS485	The max. baudrate is 115.2KHz, use Modbus RTU protocol to communicate with controller.			
CAN BUS	Support maximum 1MHz baudrate. Communicate with controller via CANopen protocol			
Mechanical dimensions(mm)	100*95*60	130*95*60	140*115*80	
Note: Including terminal space				
Weight G(Kg)	1.2	1.6	2.9	
Rated speed nN(rpm)	3000	3000	3000	
Rated torque Tn(Nm)	0.64	1.27	2.39	
Maximum torque Tm(Nm)	1.92	3.81	7.17	
Rotor moment of inertia	0.214	0.405	1.087	
Jm (Kg · cm ²)	0.218 (with brake)	0.409 (with brake)	1.099 (with brake)	
Operation Environment	Operation temperature	0~40°C		
	Storage temperature	- 10°C~70°C		
	Humidity(non-condensing)	Below 90%RH		
	Protection class	IP20		
	Installation environment	Installed in a dust-free, dry and lockable environment (such as in a electrical cabinet)		
	Installation mode	Vertical installation or horizontal installation		
	Height	Rated working altitude at 1000m or below, Above 1000m: Dcreasing 1.5% per 100m rise, maximum altitude 4000m		
Atmospheric pressure	86kpa~106kpa			

Please look forward to the listing of MD series brake models in the third quarter.

Note: □□=L: Communication port RS232, RS485
□□=C: Communication port RS232, CANopen

Wiring port description

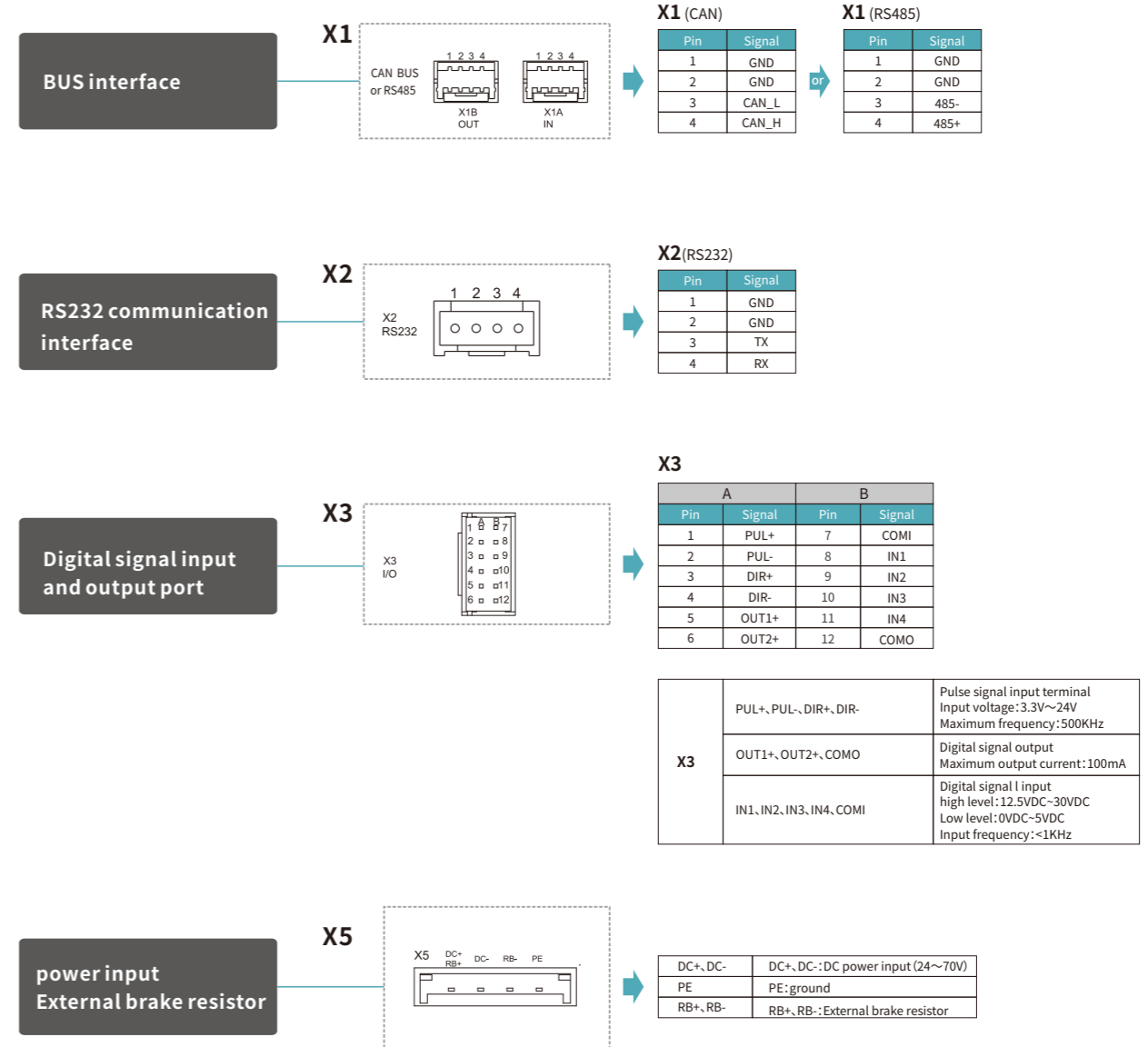

MD Series Integrated Servo Motor Butt End Model

Port	abutting end	
	Name	Specification model
X1 (CAN or RS485)	Pin	JST SZE-002T-P0.3
	Pin	JST SZE-002T-P0.3
X2 RS232	2.0mm 4P Pin	CJT A2008H-04P
	Single row of pins	CJT A2008-TP
X3 IO	Terminal (head)	CJT A2008H-2x6P
	Crimp end	CJT A2008-TP-A
X5	MD60 power transmission	Terminal (head)
	MD80 power transmission	Terminal (head)

MD Series Integrated Servo Motor

MD Series Integrated Servo Motor

MD60 Mechanical Ruler Drawing

(Unit: mm)

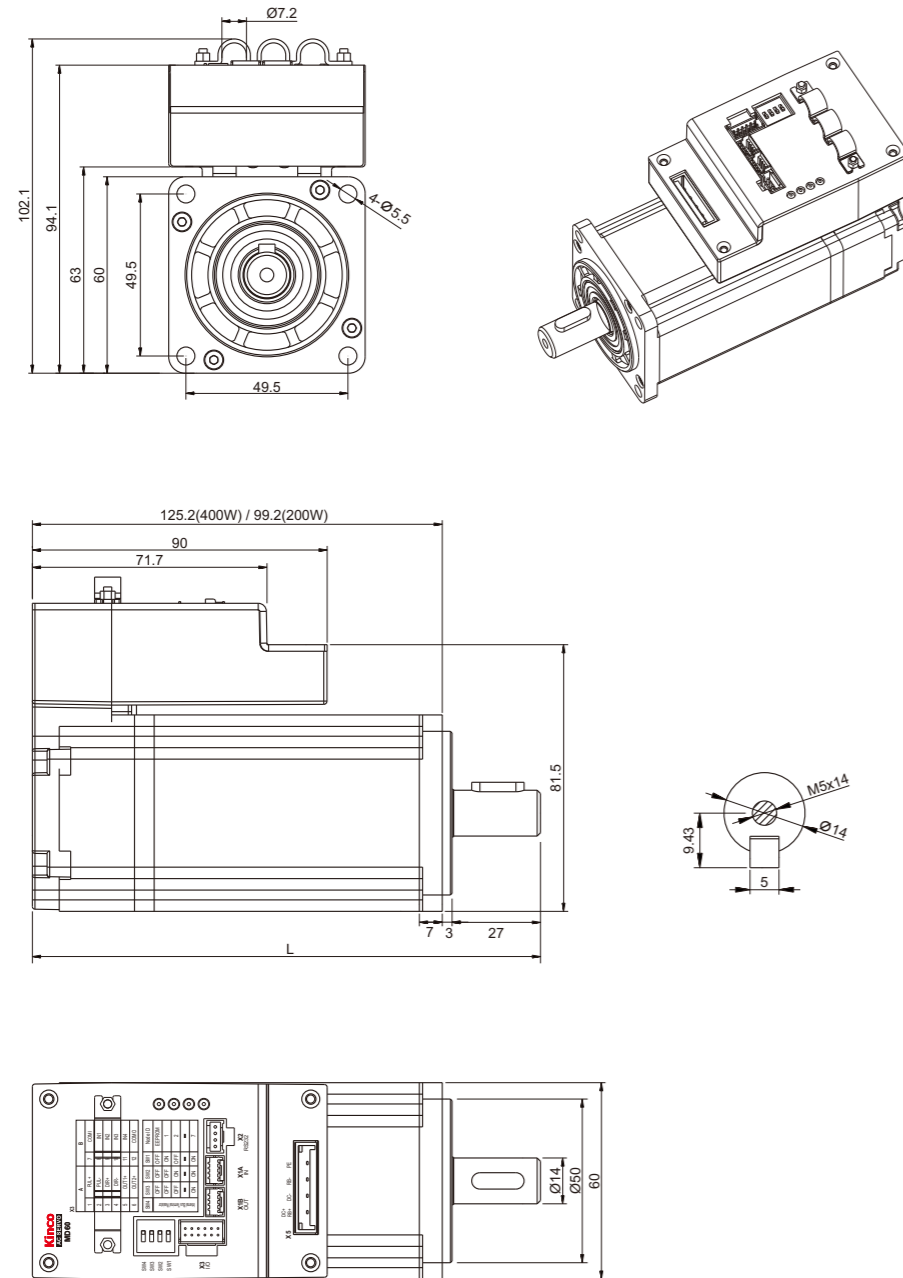

MD80 Mechanical Ruler Drawing

(Unit: mm)

