

ENP Series

Diameter ϕ 60mm shaft type ABSOLUTE Rotary encoder

■ Features

- Able to measure absolute variable angle with BCD code.
- Strong against external impact.
- Memorize the absolute position when power cut.

■ Application

- Precision numerical control machine for industrial plant.

⚠ Please read "Caution for your safety" in operation manual before using.



■ Ordering information

ENP - 1 - 1 - 1 - R - 360 - 1

Series	Output code	Output	Power supply	Rotating direction	Pulse/1Revolution	Control output
Diameter ϕ 60mm shaft type	1 : BCD code	0 : Negative logic 1 : Positive logic	0 : 5-12VDC \pm 5% 1 : 12-24VDC \pm 5%	F : Output value increase at CW direction R : Output value increase at CCW direction	006 : 6 division 016 : 16 division 008 : 8 division 024 : 24 division 012 : 12 division 360 : 360 division	1 : PNP open collector output 2 : NPN open collector output

*Since the output type is related with control output, please select the model name in specification when you order the item.

■ Specifications

Item		Diameter ϕ 60mm shaft type ABSOLUTE Rotary encoder							
Model	PNP open collector output	ENP-111□-006-1	ENP-111□-008-1	ENP-111□-012-1	ENP-111□-016-1	ENP-111□-024-1	ENP-110□-360-1		
	NPN open collector output	ENP-101□-006-2	ENP-101□-008-2	ENP-101□-012-2	ENP-101□-016-2	ENP-101□-024-2	ENP-100□-360-2		
Resolution		6 division	8 division	12 division	16 division	24 division	360 division		
Output phase	TP(Timing Pulse) : 2bit	TP(Timing Pulse) : 2bit	TP(Timing Pulse) : 2bit	TP(Timing Pulse) : 2bit	TP(Timing Pulse) : 2bit	TP(Timing Pulse) : 2bit	TS(Signal Pulse) : 10bit(BCD)		
	TS(Signal Pulse) : 4bit(BCD, EP)	TS(Signal Pulse) : 5bit(BCD, EP)	TS(Signal Pulse) : 6bit(BCD, EP)	TS(Signal Pulse) : 6bit(BCD, EP)	TS(Signal Pulse) : 7bit(BCD, EP)	TS(Signal Pulse) : 7bit(BCD, EP)			
Electrical specification	Output of phase differences	TP1:53° \pm 30' TP2:15° \pm 30' P:60° \pm 30' TS:56° \pm 30'	TP1:39° \pm 30' TP2:15° \pm 30' P:45° \pm 30' TS:42° \pm 30'	TP1:3° \pm 30' TP2:15° \pm 30' P:30° \pm 30' TS:26° \pm 30'	TP1:2° \pm 30' TP2:11.25° \pm 30' P:22.5° \pm 30' TS:19.5° \pm 30'	TP1:8° \pm 30' TP2:3° \pm 30' P:15° \pm 30' TS:11° \pm 30'	TS:1° \pm 30'		
	Control output	PNP open collector output	Output voltage : Min. (Power voltage-1.5)VDC, Load current : Max. 32mA						
		NPN open collector output	Load current : Max. 32mA, Residual voltage : Max. 1VDC						
	Response time (Rise & Fall)	PNP open collector output	TON=500ns, TOFF=Max. 2.5 μ s (Cable length:1m, I sink =32mA)						
	NPN open collector output	TON=400ns, TOFF=Max. 1.5 μ s (Cable length:1m, I sink =32mA)							
Max. Response frequency		20kHz							
Power supply		12-24VDC \pm 5% (Ripple P-P:Max. 5%)					5-12VDC \pm 5% (Ripple P-P:Max. 5%)		
Current consumption		Max. 150mA (disconnection of the load)				Max. 200mA (disconnection of the load)			
Insulation resistance		Min. 20M Ω (at 500VDC)							
Dielectric strength		500VAC 50/60Hz for 1 minute (Between all terminals and case)							
Connection		Cable outgoing connection							
Mechanical specification	Starting torque	Max. 500gf · cm(0.05N · m)							
	Moment of inertia	Max. 300g · cm ² (3 \times 10 ⁻⁵ kg · m ²)							
	Shaft loading	Radial : 10kgf, Thrust : 2.5kgf							
	Deviation of shaft position	Radial : Max. 0.1mm, Thrust : Max. 0.2mm							
	Mechanical revolution	(★Note1)		3600rpm					
Vibration		1.5mm amplitude at frequency of 10 ~ 55Hz in each of X, Y, Z directions for 2 hours							
Shock		Max. 75G							
Ambient temperature		-10 ~ 60°C (at non-freezing status), Storage:-25 ~ 85°C							
Ambient humidity		35~85%RH, Storage : 35~90%RH							
Protection		IP50(IEC specification)							
Cable		12P, ϕ 8mm, Length : 1m, Double shield cable							
Accessory		Mounting bracket, Coupling							
Weight		Approx. 577g					Approx. 690g		

※(★Note1)Max. allowable revolution \geq Max. response revolution 【Max. response revolution(rpm) = $\frac{\text{Max. response frequency}}{\text{Resolution}} \times 60 \text{ sec}$ 】

Please select the resolution to make lower max. revolution than max. allowable revolution.

Absolute $\phi 60$ Standard Shaft Type

Output waveform

6 division

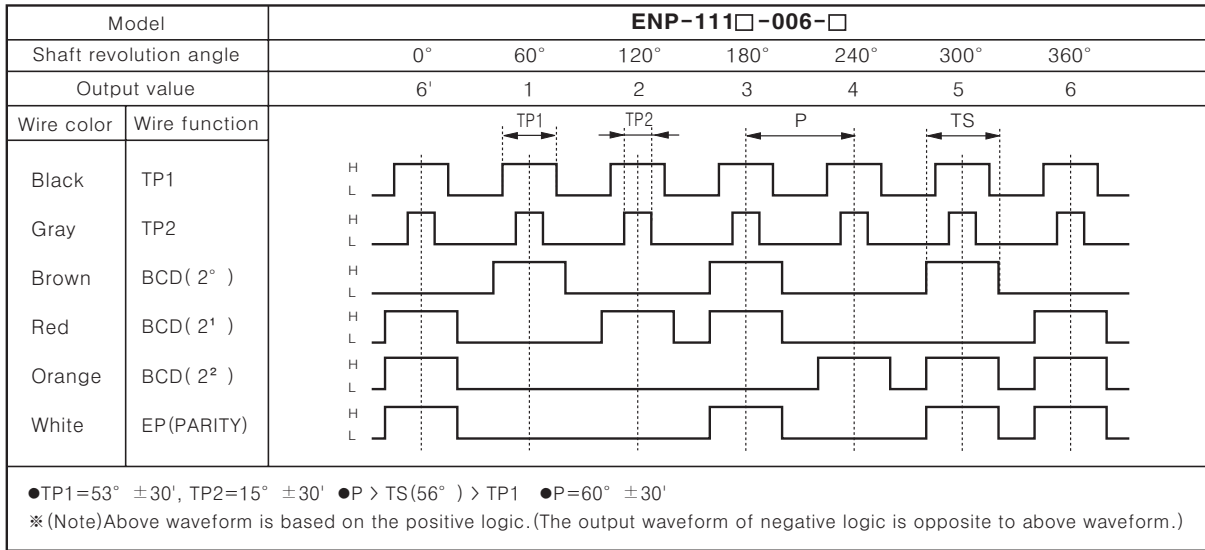

8 division

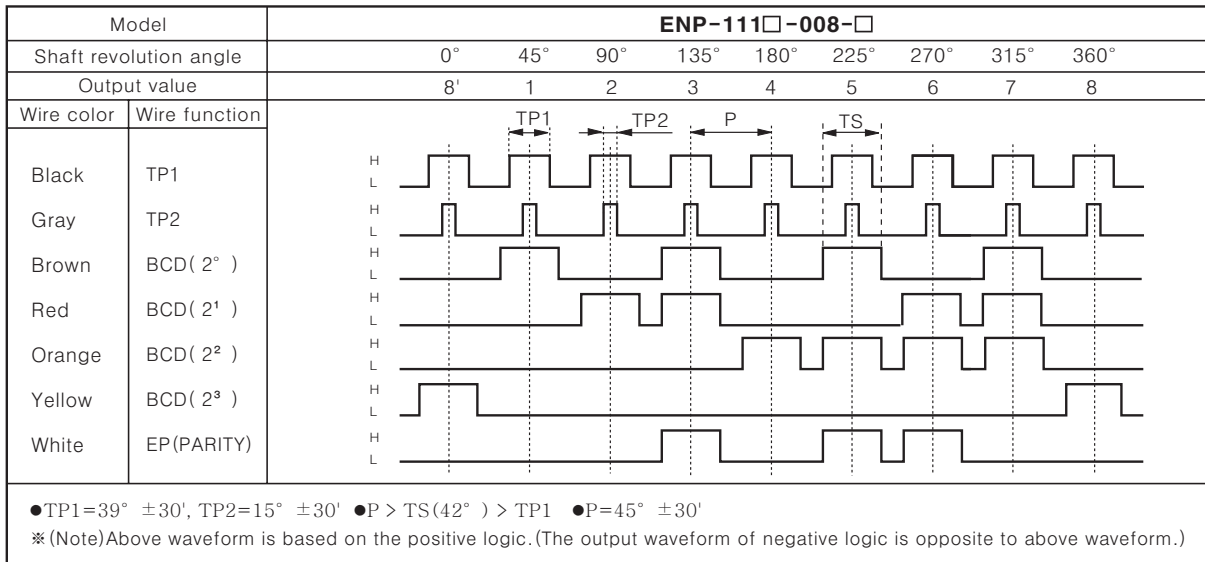

12 division

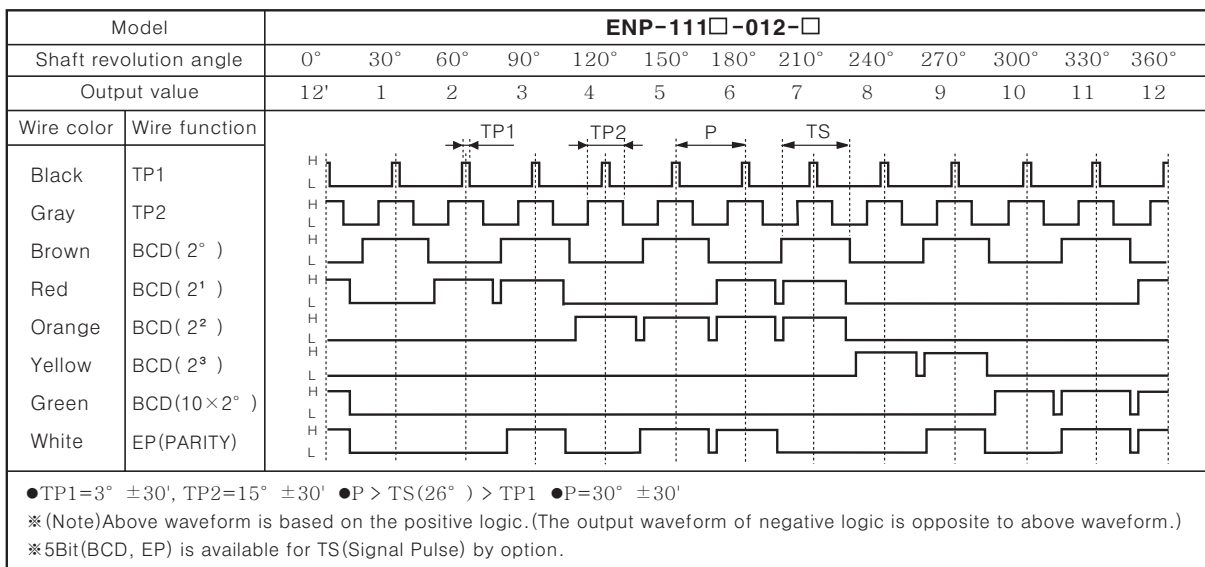

(A)
Counter

(B)
Timer

(C)
Temp.
controller

(D)
Power
controller

(E)
Panel
meter

(F)
Tacho/
Speed/
Pulse
meter

(G)
Display
unit

(H)
Sensor
controller

(I)
Proximity
sensor

(J)
Photo
electric
sensor

(K)
Pressure
sensor

(L)
Rotary
encoder

(M)
5-Phase
stepping
motor &
Driver &
Controller

ENP Series

Output waveform

●16 division

Model		ENP-111□-016-□																
Shaft revolution angle		0°	22.5°	45°	67.5°	90°	112.5°	135°	157.5°	180°	202.5°	225°	247.5°	270°	292.5°	315°	337.5°	360°
Output value		16'	1	2	3	4	5	6	7	8	9	10	11	12	13	14	15	16
Wire color	Wire function																	
Black	TP1																	
Gray	TP2																	
Brown	BCD(2°)																	
Red	BCD(2 ¹)																	
Orange	BCD(2 ²)																	
Yellow	BCD(2 ³)																	
Green	BCD(10×2°)																	
White	EP(PARITY)																	

●24 division

Model		ENP-111□-024-□																									
Shaft revolution angle		0°	15°	30°	45°	60°	75°	90°	105°	120°	135°	150°	165°	180°	195°	210°	225°	240°	255°	270°	285°	300°	315°	330°	345°	360°	
Output value		24'	1	2	3	4	5	6	7	8	9	10	11	12	13	14	15	16	17	18	19	20	21	22	23	24	
Wire color	Wire function																										
Black	TP1																										
Gray	TP2																										
Brown	BCD(2°)																										
Red	BCD(2 ¹)																										
Orange	BCD(2 ²)																										
Yellow	BCD(2 ³)																										
Green	BCD(2° × 10)																										
Blue	BCD(2 ¹ × 10)																										
White	EP(PARITY)																										
		<p>●TP1=8° ±30', TP2=3° ±30' ●P > TS(11°) > TP1 ●P=15° ±30'</p> <p>※(Note)Above waveform is based on the positive logic.(The output waveform of negative logic is opposite to above waveform.)</p>																									

●360 division

Model		ENP-100□-360-□																		
Shaft revolution angle		0°	1°	2°	3°	4°	5°	...	198°	199°	200°	201°	202°	...	356°	357°	358°	359°	360°	
Output value		0'	1	2	3	4	5	...	198	199	200	201	202	...	356	357	358	359	0	
Wire color	Wire function																			
Black	BCD(2°)																			
Brown	BCD(2 ¹)																			
Red	BCD(2 ²)																			
Orange	BCD(2 ³)																			
Yellow	BCD(2° × 10)																			
Green	BCD(2 ¹ × 10)																			
Blue	BCD(2 ² × 10)																			
Purple	BCD(2 ³ × 10)																			
Gray	BCD(2° × 100)																			
White	BCD(2 ¹ × 100)																			
		<p>●Ts=1° ±30'</p> <p>※(Note)Above waveform is based on the positive logic.(The output waveform of negative logic is opposite to above waveform.)</p>																		

Absolute $\phi 60$ Standard Shaft Type

Control output diagram

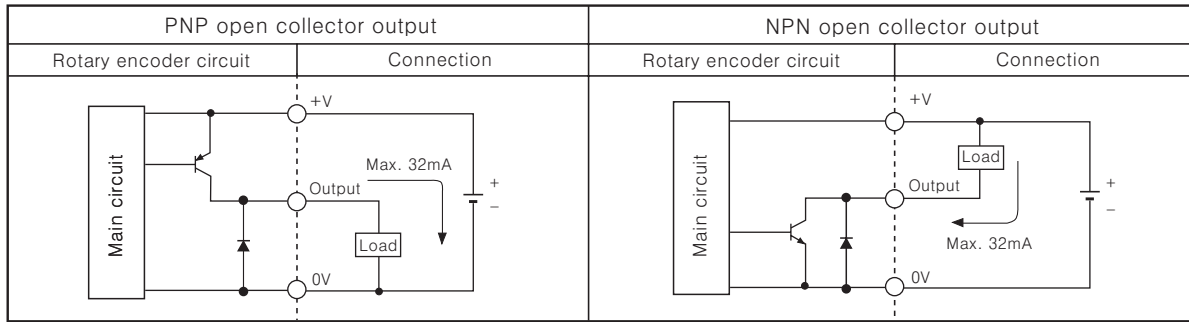

※Output circuit of all phases is the same.

Connections

Cable color	6 division	8 division	12 division	16 division	24 division	360 division
1:White	+V					
2:Black	0V					
3:Shield wire	F.G					
1:Black	TP1					BCD CODE(2 ²)
2:Brown	BCD CODE(2 ²)	BCD CODE(2 ²)	BCD CODE(2 ²)	BCD CODE(2 ²)	BCD CODE(2 ²)	BCD CODE(2 ¹)
3:Red	BCD CODE(2 ¹)	BCD CODE(2 ¹)	BCD CODE(2 ¹)	BCD CODE(2 ¹)	BCD CODE(2 ¹)	BCD CODE(2 ²)
4:Orange	BCD CODE(2 ²)	BCD CODE(2 ²)	BCD CODE(2 ²)	BCD CODE(2 ²)	BCD CODE(2 ²)	BCD CODE(2 ²)
5:Yellow	NC	BCD CODE(2 ³)	BCD CODE(2 ³)	BCD CODE(2 ³)	BCD CODE(2 ³)	BCD CODE(2 ² × 10)
6:Green	NC	NC	BCD CODE(2 ² × 10)	BCD CODE(2 ² × 10)	BCD CODE(2 ² × 10)	BCD CODE(2 ¹ × 10)
7:Blue	NC	NC	NC	NC	BCD CODE(2 ¹ × 10)	BCD CODE(2 ² × 10)
8:Purple	NC					BCD CODE(2 ³ × 10)
9:Gray	TP2					BCD CODE(2 ² × 100)
10:White	EP(PARITY)					BCD CODE(2 ¹ × 100)
11:Shield wire	F.G					

※Unused wires must be insulated.

※Encoder case and shield wire must be a good earth grounded.

※NC : Not Connected.

※Output cable must not be short-circuited due to Driver IC is used in output circuit.

Dimensions

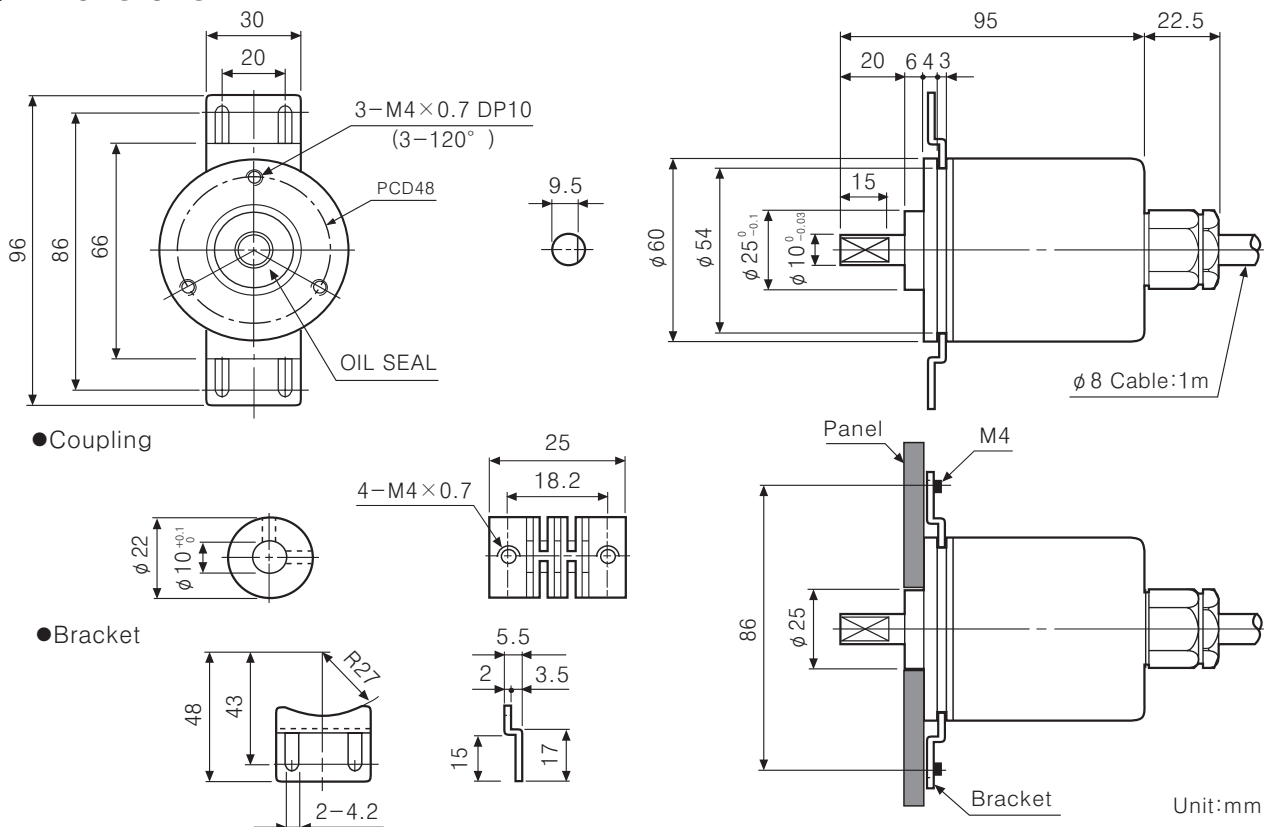

●Coupling

●Bracket

Unit:mm

(A) Counter

(B) Timer

(C) Temp. controller

(D) Power controller

(E) Panel meter

(F) Tacho/Speed/Pulse meter

(G) Display unit

(H) Sensor controller

(I) Proximity sensor

(J) Photo electric sensor

(K) Pressure sensor

(L) Rotary encoder

(M) 5-Phase stepping motor & Driver & Controller