

Absolute single-turn hollow shaft encoder

BISD flexible

Profibus-DP, CANopen, DeviceNet

features

- interface: Profibus-DP, CANopen, DeviceNet
- resolution 13 bit
- programmable operating modes
- programmable resolution and preset values
- hollow shaft \varnothing 14 mm
- compact housing

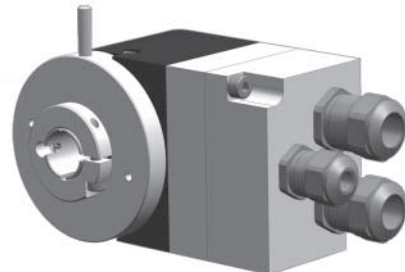

general data

voltage supply	10 - 30 VDC with reverse polarity protection
max. current supply no load	100 mA (at 24 VDC)
signal code	binary
max. resolution	13 bit (1 step = 2' 38")
max. switching frequency	800 kHz
max. error limit	$\pm 0,025^\circ$
preset	value programmable within resolution range
address	selectable via dip switches
baud rate	selectable via dip switches
direction of rotation	looking at the flange, position counts up as the shaft rotates clockwise (CW), programmable

mechanical data

max. revolutions	6'000 rpm
moment of inertia	$200 \times 10^{-6} \text{ kgm}^2$
max. protection class	IP 54
material	housing: aluminum
weight	approx. 600 g

ambient conditions

temperature range	-20...+85 °C
relative humidity	max. 95% non condensing
vibration	DIN EN 60068-2-6 ($\leq 100 \text{ m/s}^2 / 16\text{-}2'000 \text{ Hz}$)
shock	DIN EN 60068-2-27 ($\leq 2'000 \text{ m/s}^2 / 6 \text{ ms}$)
noise immunity	DIN EN 61000-6-2
emitted interference	DIN EN 61000-6-4

order designation

BISD 58 **1P24C13/00** **G** base encoder
without bus cover

shaft

K2 through hollow shaft 12 mm
KA through hollow shaft 14 mm

G with torque pin

BISD 58 **1P** **13/00** **D** complete encoder

shaft

K2 through hollow shaft 12 mm
KA through hollow shaft 14 mm

interface

24B CANopen
24D DeviceNet
24P Profibus

G with torque pin

Other versions on request.

accessories

CD-ROM with GSD-/ESD-/XML- files and manuals	part nr. 147362
spring plate for use with torque pin	part nr. 140347

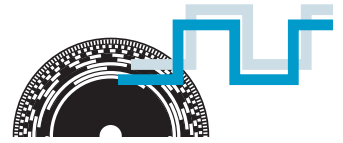

Profibus-DP, CANopen, DeviceNet

dimensions

BISD CANopen, Profibus

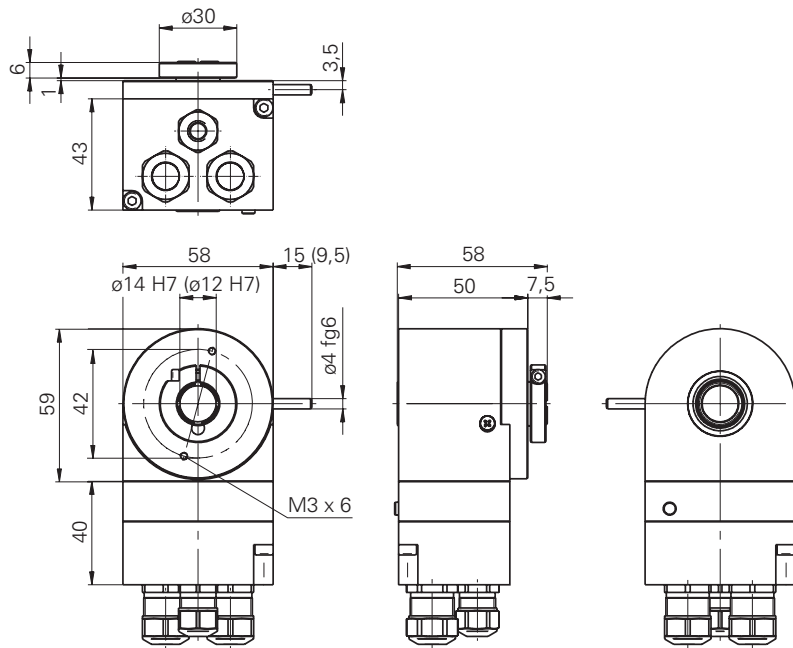

2

BISD DeviceNet

