

# IE3 Three-phase Squirrel-cage Induction motors

Y3PE / Y2PE series



# MOLL-MOTOR

MOLL-MOTOR is a family-owned and –operated enterprise with a tradition of 70 years, currently managed by a family member three generations down from the first founder Norbert Moll. The name bears a high reputation for mechatronic drive technology throughout Europe. Global producers and their products are available for our customers. MOLL-MOTOR meets customer requirements and requests for drive technology from joint planning and choice of components, to installation and commissioning. Nothing is out of scope. No technical problem is too big, and no delivery is too small. Experienced staff is available and at your service any time, according to our company philosophy: Complete mechatronic drive technology out of one hand. We successfully meet the challenges and strive for best quality, price, and timely delivery, accurate to the day. Our store measures 6.700 square meters with over 5.000 spaces for pallets, over 40.000 motors, transmissions, frequency converters and drive components.

In other words: MOLL-MOTOR, your partner for a prosperous future.

## Introduction

This catalogue contains technical data of our Y3PE and Y2PE series of motors. These motors are surface-cooled three-phase squirrel-cage induction motors (TEFC), built according to the current international IEC and EN standards. The production sites are certified to comply with the international quality standard ISO 9001.

technical terms	DIN EN	IEC
Rotating electrical machines	DIN EN 60034-1	IEC 60034-1
Terminal markings and direction of rotation	DIN EN 60034-8	IEC 60034-8
Methods of cooling (IC Code)	DIN EN 60034-6	IEC 60034-6
Dimensions and output series for rotating electrical machines	DIN EN 50347	IEC 60072
Degrees of protection provided by the integral design of rotating electrical machines (IP code) - Classification	DIN EN 60034-5	IEC 60034-5
Noise limits	DIN EN 60034-9	IEC 60034-9
Classification of types of construction, mounting arrangements and terminal box position (IM Code)	DIN EN 60034-7	IEC 60034-7
IEC standard voltages	DIN EN 60038	IEC 60038
Mechanical vibration of certain machines with shaft heights 56 mm and higher - Measurement, evaluation and limits of vibration severity	DIN EN 60034-14	IEC 60034-14
Standard methods for determining losses and efficiency from tests	DIN EN 60034-2-1	IEC 60034-2-1
Efficiency classes of line operated AC motors (IE code)	DIN EN 60034-30	IEC 60034-30

## **GENERAL INFORMATION**

**4**

International Efficiency IE, performance characteristics and other details on motor construction

General

## **TECHNICAL DATA**

**13**

Table of technical data and weights for motor power and rpm

Technical

## **GEOMETRICAL DATA**

**16**

Dimensions for connections for motors with mount or flange

Dimensions

## **AVAILABLE OPTIONS**

**21**

Design options and code (Z-)

Options

## **PRODUCT PORTFOLIO**

**22**

Overview of MOLL-MOTOR product and service programme

Product portfolio

## **SPARE PARTS**

**26**

Exploded view with spare parts numbers and names

Spare parts

## Efficiency levels IE (International Efficiency)

The European Union EuP guideline 2009/125/EC, which is based on IEC 60034-30, requires all electric motors in the range of 0,75 to 375 kW which are to be traded within the EU after 1st January 2017 to meet energy efficiency standards IE3.

Exceptions are 8-poles motors and motors of the classes S2-30 min, S3-<80%, S6-80%, operation at altitudes >4,000m above sea level, ambient temperatures <-30°C or >+60°C, ATEX motors, brake motors, pole changing motors, single-phase motors, and IE2 motors in combination with frequency converters.

MOLL-MOTOR supplies motors of the classes IE1 (standard efficiency), IE2 (high efficiency) and IE3 (premium efficiency) from local stock. Furthermore, motors of the efficiency class IE4 (super premium efficiency), reluctance motors and torque motors with matching frequency converters, as well as motors for North America according to UL/CSA (EISA) standards in IEC or NEMA frame can be supplied. Other country-specific MEPS (Minimum Energy Performance Standards) always need to be observed.

### Minimum efficiency

kW	IE1 Standard Efficiency			IE2 High Efficiency			IE3 Premium Efficiency		
	2-poles	4-poles	6-poles	2-poles	4-poles	6-poles	2-poles	4-poles	6-poles
0,75	72,1	72,1	70,0	77,4	79,6	75,9	80,7	82,5	78,9
1,1	75,0	75,0	72,9	79,6	81,4	78,1	82,7	84,1	81,0
1,5	77,2	77,2	75,2	81,3	82,8	79,8	84,2	85,3	82,5
2,2	79,7	79,7	77,7	83,2	84,3	81,8	85,9	86,7	84,3
3,0	81,5	81,5	79,7	84,6	85,5	83,3	87,1	87,7	85,6
4,0	83,1	83,1	81,4	85,8	86,6	84,6	88,1	88,6	86,8
5,5	84,7	84,7	83,1	87,0	87,7	86,0	89,2	89,6	88,0
7,5	86,0	86,0	84,7	88,1	88,7	87,2	90,1	90,4	89,1
11,0	87,6	87,6	86,4	89,4	89,8	88,7	91,2	91,4	90,3
15,0	88,7	88,7	87,7	90,3	90,6	89,7	91,9	92,1	91,2
18,5	89,3	89,3	88,6	90,9	91,2	90,4	92,4	92,6	91,7
22,0	89,9	89,9	89,2	91,3	91,6	90,9	92,7	93,0	92,2
30,0	90,7	90,7	90,2	92,0	92,3	91,7	93,3	93,6	92,9
37,0	91,2	91,2	90,8	92,5	92,7	92,2	93,7	93,9	93,3
45,0	91,7	91,7	91,4	92,9	93,1	92,7	94,0	94,2	93,7
55,0	92,1	92,1	91,9	93,2	93,5	93,1	94,3	94,6	94,1
75,0	92,7	92,7	92,6	93,8	94,0	93,7	94,7	95,0	94,6
90,0	93,0	93,0	92,9	94,1	94,2	94,0	95,0	95,2	94,9
110,0	93,3	93,3	93,3	94,3	94,5	94,3	95,2	95,4	95,1
132,0	93,5	93,5	93,5	94,6	94,7	94,6	95,4	95,6	95,4
160,0	93,7	93,8	93,8	94,8	94,9	94,8	95,6	95,8	95,6
200,0	94,0	94,0	94,0	95,0	95,1	95,0	95,8	96,0	95,8
250,0	94,0	94,0	94,0	95,0	95,1	95,0	95,8	96,0	95,8
315,0	94,0	94,0	94,0	95,0	95,1	95,0	95,8	96,0	95,8
355,0	94,0	94,0	94,0	95,0	95,1	95,0	95,8	96,0	95,8
375,0	94,0	94,0	94,0	95,0	95,1	95,0	95,8	96,0	95,8

## Motor designation

# Y3PE112M2B14F1Z-DK

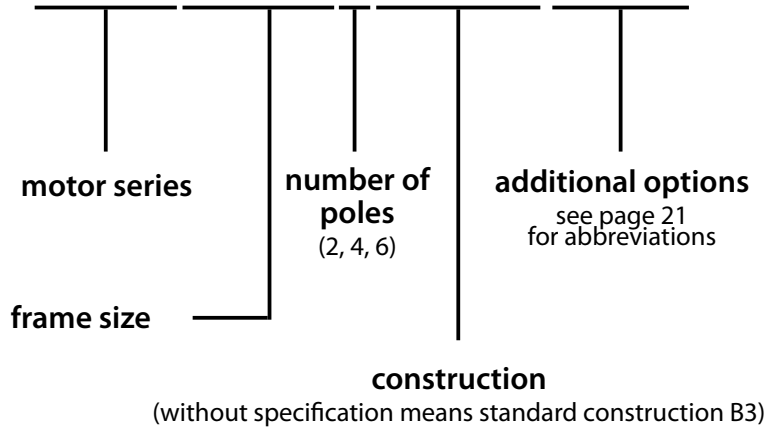

## Motor series

**Y3PE** frame size 80 - 160 / Aluminium housing  
Motors < 0,75kW and 8-pole motors ≤11kW  
are Y3-series motors (-IE1)

**Y2PE** frame size 160 - 355 / cast iron housing  
8-pole motors >11kW are Y2-series  
motors (-IE1)



## Name plate

- 1 type of machine: three-phase A.C. low voltage motor
- 2 motor type
- 3 construction type (B3, B5, B35, ...)
- 4 ambient temperature
- 5 serial number
- 6 thermal class
- 7 protection class
- 8 type of duty cycle
- 9 standards, rules and regulations
- 10 nominal power [kW]
- 11 nominal voltage [V]
- 12 nominal current [A]
- 13 nominal revolutions per minute [rpm]
- 14 power factor
- 15 efficiency

MOLL-MOTOR		IE3		CE	
1 ~Mot.	2 Type			3	
4 Tamb.	5				
6 Iso-Cl	7 IP	8 S	9 IEC/EN 60034		
50Hz		10 kW	60Hz		
		11 V			
		12 A			
		13 rpm			
		14 cos φ			
50Hz-IE3 η	15	100%	75%	50%	
60Hz-IE3 η		100%	75%	50%	
www.mollmotor.at					

## Construction types

The motors are available in the construction types IM B3, IM B5, IM B14 and IM B9 (without label on the a-side) and derived versions. They were made according to DIN EN 60034 as specified in the table below:

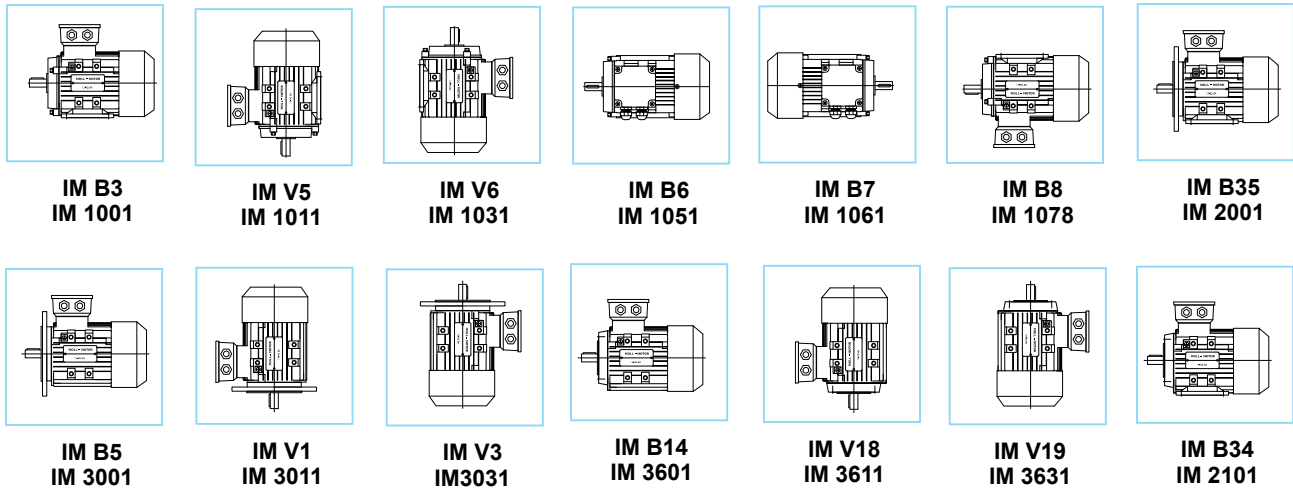

## Special constructions

Special shafts according to plans and material requirements of customers (Z-SW), oil-proof construction (Z-WD), encapsulated, potted windings (Z-VW), encoders (Z-DG), wiring according to customer requirements, etc. available on request.

## Painting

The standard painting is RAL 7030 silk-matt.

Any other colour (Z-xxxx) and epoxy resin coating (Z-EP) is available on request. Categories of corrosivity according to DIN EN ISO 12944-2 C1-C5M on request.

## Type of duty cycle

The standard motor version is designed for continuous operation at regular conditions, i.e., S1 – continuous duty with constant load. Any other duty cycle (S2 to S9) can optionally also be realised.

## Terminal Box

The terminal box is made of aluminium up to frame size 160, and beyond that out of cast iron. It can be turned in 90° increments. Beyond frame size 160, separate cable glands for signal lines are provided.

Frame size	Cable glands Connection cable	Clamping range	Cable glands signal	Connecting bolt
80	1x M25x1,5 - 1x M20x1,5	9-16mm - 6-12mm		M4 x 14mm
90	1x M25x1,5 - 1x M20x1,5	9-16mm - 6-12mm		M4 x 14mm
100	1x M25x1,5 - 1x M20x1,5	9-16mm - 6-12mm		M4 x 14mm
112	1x M25x1,5 - 1x M20x1,5	9-16mm - 6-12mm		M5 x 18mm
132	1x M32x1,5 - 1x M25x1,5	13-20mm - 9-16mm		M5 x 18mm
160	1x M40x1,5 - 1x M32x1,5	20-26mm - 13-20mm	1x M20x1,5 - 5-9mm	M6 x 29mm
180	1x M40x1,5 - 1x M32x1,5	20-26mm - 13-20mm	1x M20x1,5 - 5-9mm	M6 x 29mm
200	1x M40x1,5 - 1x M32x1,5	20-26mm - 13-20mm	1x M20x1,5 - 5-9mm	M8 x 35mm
225	2x M50x1,5	25-31mm	1x M20x1,5 - 5-9mm	M8 x 35mm
250	2x M63x1,5	29-35mm	1x M20x1,5 - 5-9mm	M10 x 39mm
280	2x M63x1,5	29-35mm	1x M20x1,5 - 5-9mm	M10 x 39mm
315	2x M63x1,5	29-35mm	1x M20x1,5 - 5-9mm	M16 x 65mm
355	2x M63x1,5	29-35mm	1x M20x1,5 - 5-9mm	M20 x 70mm

## Position of the terminal box

The mounts of motors in the range of frame size 56 to 160 (aluminium) can be removed. The mounts are attached to the frame with two screws each. The mounts can be attached on either side, so that the connection box can be positioned left or right. Adaptation to B35 or B34 can be made easily.

## Wiring diagram

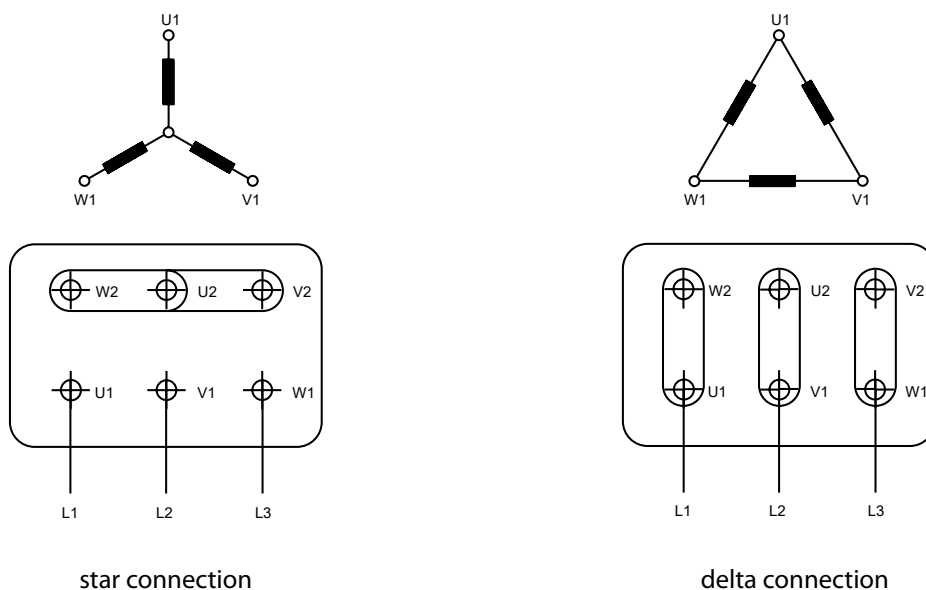

## Voltage

The standard voltage is 230 V (delta connection) / 400 V (star connection) (< 3 kW) and 400 V (delta connection) / 690 V (star connection) ( $\geq 3$  kW); frequency 50 Hz.

Motors with windings designed for these standards can be operated in a 60 Hz grid at 460 V. Nominal revolutions per minute will increase by a factor of 1,2, and nominal power will increase by a factor of 1,15.

Different voltages and frequencies can be accounted for on request (option Z-UF)

## Overload

At ambient temperature  $\leq 40^{\circ}\text{C}$ , 1,5 fold overload is tolerable for up to 15 seconds according to EN6004-1. With isolation class F, permanent overload of 12% or operation at an ambient temperature of up to  $55^{\circ}\text{C}$  are possible.

## Insulation Class

The motors standard equipment is with class F insulation materials (enamelled wire, insulation, impregnating resin). When operated in S1 conditions at standard load, the motor's temperature will never exceed 80K above ambient, as required for class B. Careful selection of insulation system components allows usage of motors in frequency inverter operations, in tropical conditions and at a normal level of vibrations

We recommend to contact our customer service office for help with choosing the right equipment, if operation in areas with aggressive chemical substances or high humidity is planned. On request, motors can also be delivered to the specifications of thermal class H.

## Type of Protection

Standard design motors are supplied with type IP55 protection. A higher level of protection is available on request (Z-IP56, Z-IP65). All motors installed outdoors must be protected from direct sunlight, irrespective of what the specific type of protection is. In case a motor is mounted vertically with the shaft pointing down, a protective cover should be ordered separately to prevent entry of water or objects.

## Fan covers / designs depend on series and size

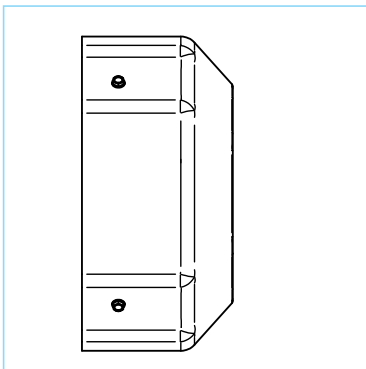

Y3PE series Alu  
Up to frame size 132

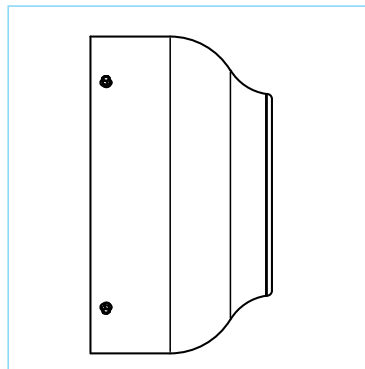

Y3PE series Alu frame size 160  
Y2PE series cast iron  
up to frame size 280

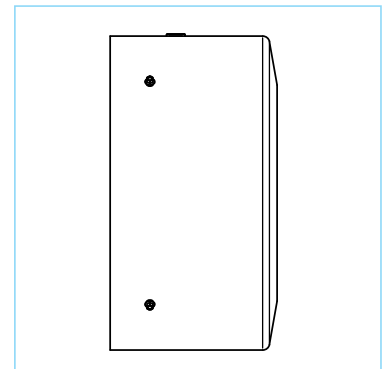

Y2PE series cast iron  
from frame size 315



## Thermal Winding Protection Provisions

Motors can be fitted with integrated temperature sensors to protect the winding from overheating when there is an overload or when ventilation is poor. Motors driven by frequency inverters always should be equipped with such protection. Available options include:

### Z-TO: Three bimetal sensors

#### with a response temperature of 150°C in the windings

This protection device consists of an encapsulated bimetal plate, which opens the circuit contact in case of overheating. The circuit automatically closes again after the temperature dropped into the specified range. Three such bimetal sensors are usually connected in series on an auxiliary terminal block.

### Z-DK: Three PTC-thermistors

#### with a response temperature of 150°C

This overheating protection is the standard for IE3 motors with frame size 132 to 355. These thermistors contain a semi-conductor which shows a big change in resistance at the temperature set for overheating protection. Generally, thermistors with a positive temperature coefficient, known as PTC, are used. The advantages of these sensors are their small size, and their precisely defined switching time and temperature. They never show signs of wear. Unlike bimetal temperature probes, thermistors do not switch the circuit relay directly, and must be combined with a special tripping unit. The three PTC-thermistors are connected in series on an auxiliary terminal block.

## Ambient Temperature

The tables in the catalogue list operation characteristics for 50 Hz for operation conditions according to DIN EN60034-1 (temperature range: -20°C – 40°C and altitude below 1,000 m above sea level). The motors can also be operated at temperatures between 40°C and 60°C. However, in that case, power deviations according to the table must be observed. Operation at ambient temperatures higher than 60°C require special motors (option Z-TA).

ambient temp. (°C)	Level above sea (m)								
	1000	1500	2000	2500	3000	3500	4000	4500	5000
-20	1,17	1,14	1,12	1,09	1,05	1,02	0,98	1,00	1,00
-15	1,17	1,14	1,12	1,09	1,05	1,02	0,98	1,00	1,00
-10	1,17	1,14	1,12	1,09	1,05	1,02	0,98	1,00	0,97
-5	1,17	1,14	1,12	1,09	1,05	1,02	0,98	0,98	0,94
0	1,17	1,14	1,12	1,09	1,05	1,02	0,98	0,96	0,93
5	1,17	1,14	1,12	1,09	1,05	1,02	0,98	0,95	0,92
10	1,17	1,14	1,12	1,09	1,05	1,02	0,98	0,94	0,91
15	1,14	1,12	1,09	1,06	1,03	0,99	0,95	0,91	0,88
20	1,12	1,09	1,06	1,03	1,00	0,96	0,92	0,88	0,85
25	1,09	1,06	1,03	1,00	0,96	0,94	0,90	0,85	0,81
30	1,06	1,03	1,00	0,97	0,93	0,91	0,87	0,82	0,78
35	1,03	1,00	0,96	0,94	0,91	0,88	0,85	0,81	0,77
40	1,00	0,97	0,94	0,91	0,88	0,84	0,82	0,80	0,76
45	0,96	0,93	0,91	0,89	0,86	0,83	0,80	0,76	0,72
50	0,93	0,90	0,87	0,85	0,82	0,80	0,77	0,72	0,67
55	0,89	0,86	0,84	0,82	0,79	0,77	0,74	0,67	0,62
60	0,85	0,83	0,81	0,78	0,76	0,74	0,71	0,65	0,61

## Cooling

Motors are cooled by self-ventilation (IC 411 in acc. with DIN EN 60034-6) and fitted with a synthetic two-way axial fan. Motors must be mounted paying attention to a minimum distance between the fan cap and the closest object, so that the air circulation is not compromised. As a rule of thumb, this minimum distance should be half the axle height. For easier access for servicing, it is recommended to keep a minimum distance matching the size of the fan cap. Starting with frame size 80, motors can be supplied with an independently driven external ventilator if required. Cooling then takes place through an axial ventilator mounted in place of the standard fan cap. This design should be used in cases where the motor is operated using a frequency inverter with a frequency lower than 25 Hz, so that the motor can be operated at constant torque at low rotation velocity, or when there is a broad range of rotation velocity. This option is not applicable for motors with a shaft on both ends.

## Lubrication

Motors of frame size 80 to 250 have permanent lubrication bearings and can be used in a dry or damp environment. Motors of frame size 280 to 355 have grease nipples for re-lubrication. The recommended lubricant is mineral oil based grease with a lithium thickener according to DIN 51825 K2K30, such as SKF LGMT2, Esso/Mobil Unirex N2/N3, Shell Gadus S 2, or similar.

## Direction of rotation

The motors can be operated in both directions of rotation. If the clamps U1, V1, W1 are connected to phases L1, L2, L3, the motor will rotate clockwise (when looking at the motor shaft). Counterclockwise direction of rotation can be realised by switching of two phases.

## Bearings

Motors of the Y3 series with aluminium frame have rotors which are centered with spring washers. Sizes 71 to 132 can be constructed with a fixed bearing on the drive end (option Z-FA and FAS). For sizes 160 and up, the non drive end has a fixed bearing. A fixed bearing on the drive end is optionally possible (Z-FAS), but causes a reduction of maximum tolerable radial load.

The following table shows the bearings used in our standard motors: Reinforced bearings for sizes 160 and up (option Z-VL), grease nipples (Z-NE) and electrically isolated bearings (Z-IL) are optionally available on request.

Frame size	Number of poles	Type of bearing DE	Type of bearing NDE
Y3PE80	2-8	6204-2RZ CM	6204-2RZ CM
Y3PE90	2-8	6205-2RZ CM	6205-2RZ CM
Y3PE100	2-8	6206-2RZ CM	6206-2RZ CM
Y3PE112	2-8	6306-2RZ C3	6306-2RZ C3
Y3PE132	2-8	6308-2RZ C3	6308-2RZ C3
Y3PE160	2-8	6309-2RZ C3	6309-2RZ C3
Y2PE160	2-8	6309-2Z C3	6309-2Z C3
Y2PE180	2-8	6311-2Z C3	6311-2Z C3
Y2PE200	2-8	6312-2Z C3	6312-2Z C3
Y2PE225	2-8	6313-2Z C3	6313-2Z C3
Y2PE250	2-8	6314-2Z C3	6314-2Z C3
Y2PE280	24-8	6314 C36317 C3	6314 C36317 C3
Y2PE315	24-8	6317 C36319 C3	6317 C36319 C3
Y2PE355	24-8	6319 C36322 C3	6319 C36322 C3

## Rotor Balancing

Motors are dynamically balanced with half a parallel key mounted and classify in vibration grade A according to DIN EN 60034-14. In case there are special requirements for balancing, a version Z-VR with reduced vibration according to grade B is available. The table summarises maximum vibration quantity as vibration amplitude  $s$ , vibration velocity  $v$ , and vibration acceleration  $a$ , per shaft height, for the vibration classes A and B.

The data refer to a freely suspended motor running without load. Tolerance range:  $\pm 10\%$

Vibration grade	Limits per vibration grade								
	56 < H ≤ 132			132 < H ≤ 280			H > 280		
	s[ $\mu\text{m}$ ]	v[mm/s]	a[mm/s <sup>2</sup> ]	s[ $\mu\text{m}$ ]	v[mm/s]	a[mm/s <sup>2</sup> ]	s[ $\mu\text{m}$ ]	v[mm/s]	a[mm/s <sup>2</sup> ]
A	25	1,6	2,5	35	2,2	3,5	45	2,8	4,4
B	11	0,7	1,1	18	1,1	1,7	29	1,8	2,8

## Tolerable bearing load

frame size	tolerable radial load point for load X = E/2				tolerable axial load B3 / horizontal shaft				tolerable axial load V1 / vertical shaft pointing down downward load				tolerable axial load V3 / vertical shaft pointing up upward load			
	2-pol kN	4-pol kN	6-pol kN	8-pol kN	2-pol kN	4-pol kN	6-pol kN	8-pol kN	2-pol kN	4-pol kN	6-pol kN	8-pol kN	2-pol kN	4-pol kN	6-pol kN	8-pol kN
56M	0,35	0,41			0,17	0,20			0,15	0,19			0,18	0,23		
63M	0,39	0,49	0,53		0,19	0,26	0,28		0,16	0,23	0,26		0,21	0,29	0,31	
71M	0,45	0,56	0,66	0,71	0,23	0,34	0,34	0,36	0,20	0,32	0,30	0,35	0,26	0,37	0,37	0,40
80M	0,64	0,84	0,86	0,98	0,34	0,45	0,48	0,52	0,29	0,45	0,45	0,48	0,36	0,48	0,50	0,56
90S	0,69	0,99	1,01	1,12	0,40	0,55	0,58	0,63	0,36	0,50	0,52	0,59	0,43	0,57	0,62	0,67
90L	0,72	1,02	1,03	1,15	0,38	0,52	0,55	0,59	0,33	0,49	0,51	0,56	0,41	0,55	0,58	0,63
100L	0,93	1,34	1,39	1,49	0,50	0,70	0,72	0,80	0,45	0,66	0,67	0,72	0,57	0,77	0,79	0,84
112M	0,98	1,42	1,47	1,56	0,52	0,74	0,75	0,83	0,45	0,62	0,64	0,76	0,63	0,82	0,85	0,94
132S	1,43	1,98	2,08	2,24	0,86	1,18	1,21	1,35	0,64	0,90	0,95	1,10	1,06	1,42	1,45	1,52
132M	1,47	2,03	2,12	2,32	0,83	1,14	1,19	1,32	0,61	0,86	0,93	1,06	1,04	1,37	1,41	1,50
160M	1,57	2,19	2,26	2,54	0,86	1,17	1,23	1,35	0,50	0,81	0,85	1,00	1,22	1,57	1,65	1,68
160L	1,62	2,23	2,31	2,59	0,83	1,14	1,20	1,30	0,46	0,77	0,83	0,96	1,17	1,54	1,62	1,65
180M	2,95	4,41	4,57	4,68	0,85	1,16	1,25	1,32	0,45	0,77	0,82	0,95	1,21	1,62	1,68	1,67
180L	2,98	4,46	4,61	4,71	0,83	1,13	1,23	1,28	0,43	0,76	0,80	0,92	1,18	1,59	1,65	1,63
200L	5,18	6,83	8,09	8,85	0,83	1,18	1,24	1,36	0,42	0,73	0,80	0,99	1,30	1,63	1,67	1,72
225S	6,15	7,83	9,01	10,15	1,12	1,63	1,93	2,40	0,32	0,71	1,05	1,57	2,14	2,64	2,95	3,45
225M	6,18	7,85	9,05	10,19	1,08	1,60	1,89	2,35	0,31	0,70	1,00	1,52	2,08	2,58	2,87	3,40
250M	6,85	8,80	10,43	11,56	1,02	1,63	2,00	2,60	0,21	0,60	1,12	1,55	2,28	2,70	3,20	3,70
280S	7,78	11,85 15,7(NU)	13,78 15,6(NU)	15,37 15,6(NU)	1,74	1,95	2,45	2,95	0,16	0,32	0,84	1,05	2,94	3,15	3,65	3,90
280M	7,83	11,92 15,7(NU)	13,86 15,6(NU)	15,46 15,6(NU)	1,71	1,90	2,40	2,85	0,15	0,30	0,78	1,00	2,90	3,08	3,55	3,85
315S	7,06	9,93 11,43(NU)	11,23 13,45(NU)	12,78 15,28(NU)	2,06	5,40	6,60	7,70	1,05	1,90	2,45	2,90	3,65	8,10	9,25	7,50
315M	7,03	9,72 11,48(NU)	11,05 13,41(NU)	12,59 15,22(NU)	2,00	5,40	6,60	7,70	1,00	1,85	2,35	2,83	3,55	7,90	9,15	7,40
315L	7,03	9,72 11,48(NU)	11,05 13,41(NU)	12,59 15,22(NU)	2,00	5,40	6,60	7,70	1,00	1,85	2,35	2,83	3,55	7,90	9,15	7,40
355M	8,45	10,96 13,28(NU)	13,26 14,86(NU)	14,75 17,03(NU)	3,95	5,80	7,00	7,00	1,25	2,13	3,05	3,86	4,40	10,30	12,40	9,60
355L	8,45	10,96 13,28(NU)	13,26 14,86(NU)	14,75 17,03(NU)	3,95	5,80	7,00	7,00	1,25	2,13	3,05	3,86	4,40	10,30	12,40	9,60

## Tolerance for technical data according to DIN EN 60034-1

<b>Level of efficiency</b>	-0,15(1- $\eta$ ) $P \leq 150 \text{ kW}$
<b>Power factor</b>	- (1-cos $\varphi$ )/6 min. 0,02 max. 0,07
<b>Slip</b>	$\pm 20\%$ $P \geq 1 \text{ kW}$ ; $\pm 30\%$ $\leq 1 \text{ kW}$
<b>Starting current</b>	+20%
<b>Starting current</b>	-15% +25%
<b>Max. torque</b>	-10%

## Geometric tolerance

The shaft ends, parallel keys and flanges meet the dimension and tolerance requirements specified in EN 50347 and IEC 60072. The shaft ends have a threaded borehole according to UNI 3221 and DIN 332 and a mounted parallel key. The following table specifies the tolerances for the various parts:

Component	Dimensions	Tolerance	
Shaft height	H	Up to frame size BG 250 above frame size 250	0,5 mm 1 mm
Shaft end	D	$\emptyset 19 - 28 \emptyset 38 - 48 \geq \emptyset 55$	j6k6m6
key	F		h9
flange	N	$\emptyset < 250 \emptyset \geq 250$	j6h6

# 2 polig

# 400V/50Hz

# 3000 rpm

P [kW]	Motortype	n [rpm]	voltage [V]	$\eta$ 100%	$\eta$ 75%	$\eta$ 50%	cos $\phi$	Inertia [kgm <sup>2</sup> ]	I <sub>n</sub> (at 400V)	Mn [Nm]	I <sub>n</sub> /I <sub>n</sub>	M <sub>n</sub> /M <sub>n</sub>	M <sub>n</sub> /M <sub>n</sub>	LpA 50Hz (dB(A))	Weight B3 [kg]
0,75	Y3PE80A2	2890	230/400	81,0	81,3	79,6	0,82	0,0011	1,6	2,5	7,0	2,3	2,3	56	11
1,1	Y3PE80B2	2890	230/400	83,0	83,5	82,1	0,83	0,0014	2,3	3,6	7,3	2,2	2,3	56	12
1,5	Y3PE90S2	2890	230/400	84,5	85,5	83,8	0,84	0,0022	3,1	5,0	7,6	2,2	2,3	61	19
2,2	Y3PE90L2	2890	230/400	86,1	86,7	85,4	0,85	0,0028	4,3	7,3	7,6	2,2	2,3	61	22
3	Y3PE100L2	2895	400/690	87,4	87,9	86,6	0,87	0,0046	5,7	9,9	7,8	2,2	2,3	65	28
4	Y3PE112M2	2910	400/690	88,2	88,6	87,4	0,88	0,0063	7,4	13,1	8,3	2,2	2,3	66	36
5,5	Y3PE132SA2	2940	400/690	89,4	89,7	88,6	0,88	0,0139	10,1	17,9	8,3	2,2	2,3	69	49
7,5	Y3PE132SB2	2940	400/690	90,3	90,9	89,6	0,89	0,0164	13,5	24,4	7,9	2,2	2,3	69	54
11	Y3PE160MA2	2950	400/690	91,3	91,5	89,9	0,89	0,0540	19,6	35,6	8,1	2,2	2,3	75	96
15	Y3PE160MB2	2950	400/690	92,0	92,3	91,2	0,89	0,0618	26,5	48,6	8,1	2,2	2,3	75	110
18,5	Y3PE160L2	2950	400/690	92,6	92,8	91,6	0,89	0,0716	32,5	60,0	8,2	2,2	2,3	75	123
11	Y2PE160MA2	2950	400/690	92,7	92,9	91,8	0,89	0,0540	19,6	36,0	8,1	2,2	2,3	70	124
15	Y2PE160MB2	2950	400/690	93,4	93,6	92,2	0,89	0,0618	26,5	49,0	8,1	2,2	2,3	70	140
18,5	Y2PE160L2	2950	400/690	92,6	92,8	91,6	0,89	0,0716	32,5	60,0	8,2	2,2	2,3	70	160
22	Y2PE180M2	2960	400/690	92,7	92,9	91,8	0,89	0,0892	38,5	71,0	8,2	2,0	2,3	72	200
30	Y2PE200LA2	2970	400/690	93,4	93,6	92,2	0,89	0,1800	52,0	96,0	7,6	2,0	2,3	73	262
37	Y2PE200LB2	2970	400/690	93,7	93,9	92,6	0,89	0,1900	64,0	119,0	7,6	2,0	2,3	73	273
45	Y2PE225M2	2970	400/690	94,1	94,0	92,7	0,90	0,3335	77,0	145,0	7,7	2,0	2,3	75	357
55	Y2PE250M2	2980	400/690	94,3	94,5	92,9	0,90	0,4638	94,0	176,0	7,7	2,0	2,3	78	432
75	Y22PE280S2Z-NE	2980	400/690	94,7	94,5	93,6	0,90	1,0889	127,0	240,0	7,1	2,0	2,3	80	535
90	Y22PE280M2Z-NE	2980	400/690	95,0	95,2	94,3	0,90	1,1487	152,0	288,0	7,1	2,0	2,3	80	562
110	Y2PE315S2Z-NE	2980	400/690	95,2	95,3	94,5	0,90	1,4950	185,0	353,0	7,1	1,8	2,2	81	905
132	Y2PE315M2Z-NE	2980	400/690	95,4	95,5	94,6	0,90	2,1110	222,0	423,0	7,1	1,8	2,2	81	942
160	Y2PE315LA2Z-NE	2980	400/690	95,7	95,6	94,8	0,91	2,3940	265,0	513,0	7,2	1,8	2,2	81	997
200	Y2PE315LB2Z-NE	2980	400/690	95,9	95,8	94,9	0,91	2,6540	331,0	641,0	7,2	1,8	2,2	81	1.128
250	Y2PE355M2Z-NE	2980	400/690	95,9	95,8	94,9	0,91	3,3450	414,0	801,0	7,2	1,6	2,2	89	1.779
315	Y2PE355L2-NE	2980	400/690	95,9	95,8	94,9	0,91	3,9030	522,	1009,0	7,2	1,6	2,2	89	1.845

# 4-poles

# 400V/50Hz

# 1500 rpm

P [kW]	Motor type	n [rpm]	voltage [V]	$\eta$ 100%	$\eta$ 75%	$\eta$ 50%	cos $\varphi$	Inertia [kgm <sup>2</sup> ]	I <sub>M</sub> (at 400V)	M <sub>in</sub> [Nm]	I <sub>A</sub> / I <sub>N</sub>	M <sub>A</sub> / M <sub>N</sub>	M <sub>A</sub> / M <sub>N</sub>	Lp4 50Hz [dB(A)]	Weight B3 [kg]
0,75	Y3PE80B4	1430	230/400	82,7	82,9	81,5	0,75	0,0027	1,8	5,0	6,6	2,4	2,3	47	14
1,1	Y3PE90S4	1440	230/400	84,6	84,9	83,0	0,76	0,0033	2,5	7,3	6,8	2,4	2,3	50	18
1,5	Y3PE90L4	1440	230/400	85,6	86,2	84,8	0,77	0,0041	3,3	10,0	7,0	2,4	2,3	50	22
2,2	Y3PE100LA4	1455	230/400	86,9	87,4	85,9	0,81	0,0084	4,5	14,4	7,6	2,4	2,3	53	29
3	Y3PE100LB4	1455	400/690	87,8	88,2	87,1	0,82	0,0101	6,0	19,7	7,6	2,4	2,3	53	34
4	Y3PE112M4	1460	400/690	88,7	89,4	87,9	0,82	0,0139	7,9	26,2	7,8	2,3	2,3	54	40
5,5	Y3PE132S4	1470	400/690	89,8	90,2	89,1	0,83	0,0310	10,7	35,7	7,9	2,3	2,3	60	55
7,5	Y3PE132M4	1470	400/690	90,4	91,0	90,0	0,84	0,0398	14,3	48,7	7,5	2,3	2,3	60	65
11	Y3PE160M4	1470	400/690	91,4	91,7	90,8	0,85	0,0852	20,4	71,0	7,5	2,2	2,3	64	109
15	Y3PE160L4	1470	400/690	92,2	92,5	91,5	0,86	0,1116	27,3	97,0	7,8	2,2	2,3	64	126
11	Y2PE160M4	1470	400/690	91,4	91,7	90,8	0,85	0,0852	20,4	71,0	7,5	2,2	2,3	62	137
15	Y2PE160L4	1470	400/690	92,2	92,5	91,5	0,86	0,1116	27,3	97,0	7,8	2,2	2,3	62	163
18,5	Y2PE180M4	1475	400/690	92,7	93,0	92,1	0,86	0,1679	33,5	120,0	7,8	2,2	2,3	65	192
22	Y2PE180L4	1475	400/690	93,0	93,3	92,4	0,86	0,2065	39,7	142,0	7,8	2,2	2,3	65	222
30	Y2PE200L4	1480	400/690	93,6	93,4	92,4	0,86	0,3147	54,0	194,0	7,8	2,2	2,3	65	279
37	Y2PE225S4	1485	400/690	93,9	94,0	93,2	0,86	0,5224	66,0	238,0	7,4	2,2	2,3	67	342
45	Y2PE225M4	1485	400/690	94,3	94,6	93,4	0,86	0,6118	80,0	289,0	7,4	2,2	2,3	67	390
55	Y2PE250M4	1485	400/690	94,6	94,8	93,6	0,86	0,8294	98,0	354,0	7,4	2,2	2,3	68	450
75	Y22PE280S4Z-NE	1485	400/690	95,0	95,1	94,2	0,88	2,1199	129,0	482,0	6,9	2,2	2,3	69	587
90	Y22PE280M4Z-NE	1485	400/690	95,2	95,4	94,5	0,88	2,5634	155,0	579,0	6,9	2,2	2,3	69	661
110	Y2PE315S4Z-NE	1485	400/690	95,5	95,4	94,7	0,89	3,6260	187,0	707,0	7,0	2,1	2,2	77	908
132	Y2PE315M4Z-NE	1485	400/690	95,7	95,6	94,8	0,89	4,2100	224,0	849,0	7,0	2,1	2,2	77	1.014
160	Y2PE315LA4Z-NE	1485	400/690	95,9	95,8	94,9	0,89	4,6050	271,0	1029,0	7,1	2,1	2,2	77	1.082
200	Y2PE315LB4Z-NE	1485	400/690	96,0	95,9	94,9	0,90	5,2740	334,0	1286,0	7,1	2,1	2,2	77	1.174
250	Y2PE355M4Z-NE	1490	400/690	96,0	95,9	95,0	0,90	7,2480	418,0	1602,0	7,1	2,1	2,2	84	1.766
315	Y2PE355L4Z-NE	1490	400/690	96,0	95,9	95,0	0,90	9,1430	526,0	2019,0	7,1	2,1	2,2	84	1.822

# 6 polig

# 400V/50Hz

# 1000 rpm

$P$ [kW]	Motor type	$n$ [rpm]	Spannung [V]	$\eta$ 100%	$\eta$ 75%	$\eta$ 50%	$\cos \varphi$	Inertia [kgm <sup>2</sup> ]	$I_M$ (at 400V)	Min [Nm]	$I_A / I_N$	$M_A / M_N$	$M_A' / M_N$	$LpA$ 50Hz [db(A)]	weight B3 [kg]
0,75	Y3PE90S6	955	230/400	79,4	79,8	77,9	0,71	0,0041	1,9	7,5	6,0	2,0	2,1	46	19
1,1	Y3PE90L6	955	230/400	81,3	81,8	79,8	0,73	0,0058	2,7	11,0	6,0	2,0	2,1	46	23
1,5	Y3PE100L6	955	230/400	82,7	83,4	81,7	0,73	0,0116	3,6	15,0	6,5	2,0	2,1	50	29
2,2	Y3PE112M6	970	230/400	84,4	84,7	83,0	0,74	0,0164	5,1	21,7	6,6	2,0	2,1	54	35
3	Y3PE132S6	970	400/690	86,0	86,4	84,9	0,74	0,0346	6,8	29,5	6,8	2,1	2,1	58	49
4	Y3PE132MA6	970	400/690	86,9	87,5	86,2	0,74	0,0429	9,0	39,4	6,8	2,1	2,1	58	61
5,5	Y3PE132MB6	970	400/690	88,1	88,5	87,5	0,75	0,0537	12,0	54,0	7,0	2,1	2,1	58	68
7,5	Y3PE160M6	980	400/690	89,2	89,6	88,4	0,79	0,1064	15,4	73,0	7,0	2,0	2,1	62	100
11	Y3PE160L6	980	400/690	90,4	90,9	89,6	0,80	0,1403	22,0	107,0	7,2	2,0	2,1	62	121
7,5	Y2PE160M6	980	400/690	89,2	89,6	88,4	0,79	0,1064	15,4	73,0	7,0	2,0	2,1	62	121
11	Y2PE160L6	980	400/690	90,4	90,9	89,6	0,80	0,1403	22,0	107,0	7,2	2,0	2,1	62	158
15	Y2PE180L6	980	400/690	91,3	91,5	90,3	0,81	0,2504	29,3	146,0	7,3	2,0	2,1	62	212
18,5	Y2PE200LA6	985	400/690	91,7	92,0	90,7	0,81	0,3699	36,0	179,0	7,3	2,1	2,1	62	258
22	Y2PE200LB6	985	400/690	92,3	92,6	91,2	0,81	0,4207	42,5	213,0	7,4	2,0	2,1	63	278
30	Y2PE225M6	985	400/690	92,9	93,2	92,2	0,83	0,6236	56,0	291,0	6,9	2,0	2,1	65	340
37	Y2PE250M6	990	400/690	93,4	93,5	92,7	0,84	0,9685	68,0	357,0	7,1	2,1	2,1	67	413
45	Y22PE280S6Z-NE	990	400/690	93,8	93,7	92,9	0,85	1,9119	82,0	434,0	7,3	2,1	2,0	67	501
55	Y22PE280M6Z-NE	990	400/690	94,1	94,2	93,2	0,86	2,3411	98,0	531,0	7,3	2,1	2,0	72	563
75	Y2PE315S6Z-NE	990	400/690	94,7	94,6	93,4	0,84	4,5830	136,0	723,0	6,6	2,0	2,0	72	828
90	Y2PE315M6Z-NE	990	400/690	95,0	94,9	93,6	0,85	5,3300	161,0	868,0	6,7	2,0	2,0	72	947
110	Y2PE315LA6Z-NE	990	400/690	95,1	95,0	93,9	0,85	6,0770	196,0	1061,0	6,7	2,0	2,0	72	1.042
132	Y2PE315LB6Z-NE	990	400/690	95,5	95,4	94,1	0,86	6,8240	232,0	1273,0	6,8	2,0	2,0	74	1.136
160	Y2PE355MA6Z-NE	990	400/690	95,6	95,5	94,2	0,86	10,5930	281,0	1543,0	6,8	1,9	2,0	74	1.543
200	Y2PE355MB6Z-NE	990	400/690	95,8	95,7	94,5	0,87	11,5960	346,0	1929,0	6,8	1,9	2,0	74	1.709
250	Y2PE355L6Z-NE	990	400/690	95,8	95,7	94,6	0,87	13,8260	433,0	2412,0	6,8	1,9	2,0	74	1.884

General

Technical

Dimensions

Options

Product portfolio

Spare parts

# B3

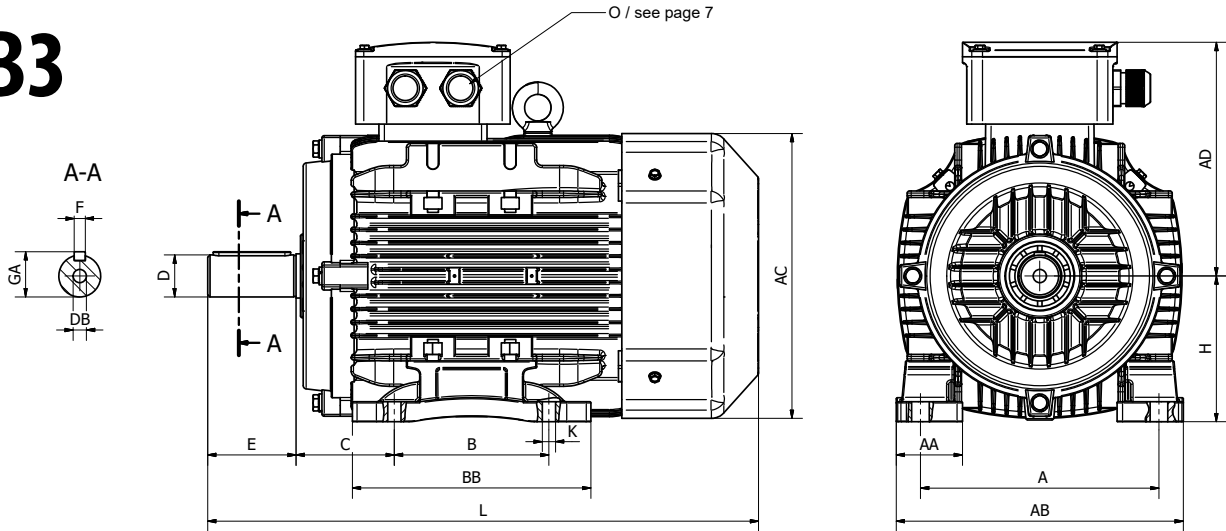

Frame size	Poles	A	B	C	D	E	F	H	K	L	AA	AB	AC	AD	BB	GA	DB
Y3PE80	2/4/6	125	100	50	19	40	6	80	10	299	37	165	158	138	130	21,5	M6x16
Y3PE90S	2/4/6	140	100	56	24	50	8	90	10	353	37	180	177	152	140	27,0	M8x19
Y3PE90L	2/4/6	140	125	56	24	50	8	90	10	373	37	180	177	152	170	27,0	M8x19
Y3PE100L	2/4/6	160	140	63	28	60	8	100	12	433	40	205	197	180	190	31,0	M10x22
Y3PE112M	2/4/6	190	140	70	28	60	8	112	12	461	50	230	218	181	200	31,0	M10x22
Y3PE132S	2/4/6	216	140	89	38	80	10	132	12	499	60	260	258	212	216	41,0	M12x28
Y3PE132M	2/4/6	216	178	89	38	80	10	132	12	522	60	260	258	212	256	41,0	M12x28
Y3PE160M	2/4/6	254	210	108	42	110	12	160	15	630	60	315	314	251	260	45,0	M16x36
Y3PE160L	2/4/6	254	254	108	42	110	12	160	15	677	60	320	314	251	304	45,0	M16x36
Y2PE160M	2/4/6	254	210	108	42	110	12	160	15	657	60	315	314	255	260	45,0	M16x36
Y2PE160L	2/4/6	254	254	108	42	110	12	160	15	725	70	320	314	255	340	45,0	M16x36
Y2PE180M	2/4/6	279	241	121	48	110	14	180	15	740	70	355	355	280	350	51,5	M16x36
Y2PE180L	2/4/6	279	279	121	48	110	14	180	15	810	70	355	355	280	382	51,5	M16x36
Y2PE200L	2/4/6	318	305	133	55	110	16	200	19	852	70	395	397	305	370	59,0	M20x42
Y2PE225S	4	356	286	149	60	140	18	225	19	874	75	435	445	335	395	64,0	M20x42
Y2PE225M	2	356	311	149	55	110	18	225	19	890	75	435	445	335	440	59,0	M20x42
	4/6	356	311	149	60	140	18	225	19	915	75	435	445	335	440	64,0	M20x42
Y2PE250M	2	406	349	168	60	140	18	250	24	985	80	490	485	370	440	64,0	M20x42
	4/6	406	349	168	65	140	18	250	24	985	80	490	485	370	440	69,0	M20x42
Y22PE280SZ-NE	2	457	368	190	65	140	18	280	24	1.045	85	550	547	410	480	69,0	M20x42
	4/6	457	368	190	75	140	20	280	24	1.045	85	550	547	410	480	79,5	M20x42
Y22PE280MZ-NE	2	457	419	190	65	140	18	280	24	1.095	85	550	547	410	536	69,0	M20x42
	4/6	457	419	190	75	140	20	280	24	1.095	85	550	547	410	536	79,5	M20x42
Y2PE315SZ-NE	2	508	406	216	65	140	18	315	28	1.185	120	635	620	530	570	69,0	M20x42
	4/6	508	406	216	80	170	22	315	28	1.220	120	635	620	530	570	85,0	M20x42
Y2PE315MZ-NE	2	508	457	216	65	140	18	315	28	1.290	120	635	620	530	680	69,0	M20x42
	4/6	508	457	216	80	170	22	315	28	1.325	120	635	620	530	680	85,0	M20x42
Y2PE315LZ-NE	2	508	508	216	65	140	18	315	28	1.290	120	635	620	530	680	69,0	M20x42
	4/6	508	508	216	80	170	22	315	28	1.325	120	635	620	530	680	85,0	M20x42
Y2PE355MZ-NE	2	610	560	254	75	140	20	355	28	1.500	116	735	698	655	760	79,5	M20x42
	4/6	610	560	254	95	170	25	355	28	1.530	116	735	698	655	760	100	M20x42
Y2PE355MZ-SWNE	4/6	610	560	254	100	210	28	355	28	1.570	116	735	698	655	760	106	M24x56
Y2PE355LZ-NE	2	610	630	254	75	140	20	355	28	1.500	116	740	698	655	760	79,5	M20x42
	4/6	610	630	254	95	170	25	355	28	1.530	116	740	698	655	760	100	M20x42
Y2PE355LZ-SWNE	4/6	610	630	254	100	210	28	355	28	1.570	116	740	698	655	760	106	M24x56



# B35

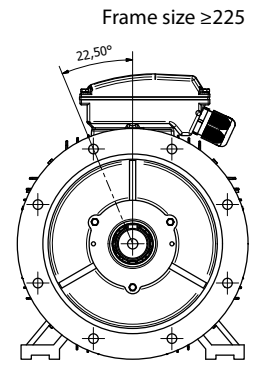
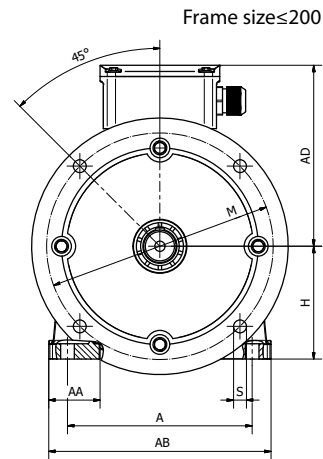
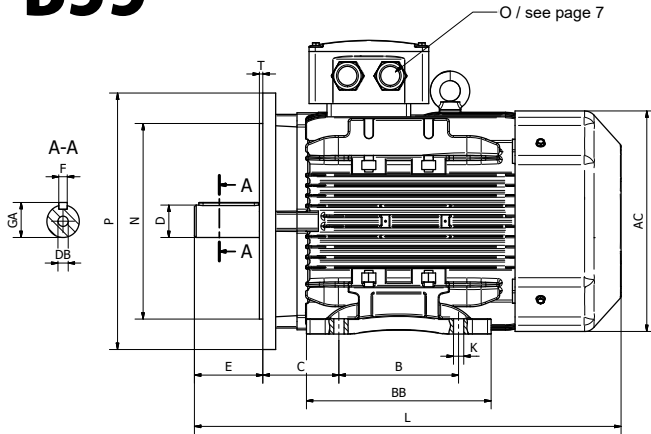

Frame size	poles	A	B	C	D	E	F	H	K	M	N	P	S	T	L	AA	AB	AC	AD	BB	GA	DB
Y3PE80	2/4/6	125	100	50	19	40	6	80	10	165	130	200	12	3,5	299	37	165	158	138	130	21,5	M6x16
Y3PE90S	2/4/6	140	100	56	24	50	8	90	10	165	130	200	12	3,5	353	37	180	177	152	140	27,0	M8x19
Y3PE90L	2/4/6	140	125	56	24	50	8	90	10	165	130	200	12	3,5	373	37	180	177	152	170	27,0	M8x19
Y3PE100L	2/4/6	160	140	63	28	60	8	100	12	215	180	250	15	4,0	433	40	205	197	180	190	31,0	M10x22
Y3PE112M	2/4/6	190	140	70	28	60	8	112	12	215	180	250	15	4,0	461	50	230	218	181	200	31,0	M10x22
Y3PE132S	2/4/6	216	140	89	38	80	10	132	12	265	230	300	15	4,0	499	60	260	258	212	216	41,0	M12x28
Y3PE132M	2/4/6	216	178	89	38	80	10	132	12	265	230	300	15	4,0	522	60	260	258	212	256	41,0	M12x28
Y3PE160M	2/4/6	254	210	108	42	110	12	160	15	300	250	350	19	5,0	630	60	315	314	251	260	45,0	M16x36
Y3PE160L	2/4/6	254	254	108	42	110	12	160	15	300	250	350	19	5,0	677	60	320	314	251	304	45,0	M16x36
Y2PE160M	2/4/6	254	210	108	42	110	12	160	15	300	250	350	19	5,0	657	60	315	314	255	260	45,0	M16x36
Y2PE160L	2/4/6	254	254	108	42	110	12	160	15	300	250	350	19	5,0	725	70	320	314	255	340	45,0	M16x36
Y2PE180M	2/4/6	279	241	121	48	110	14	180	15	300	250	350	19	5,0	740	70	355	355	280	350	51,5	M16x36
Y2PE180L	2/4/6	279	279	121	48	110	14	180	15	300	250	350	19	5,0	810	70	355	355	280	382	51,5	M16x36
Y2PE200L	2/4/6	318	305	133	55	110	16	200	19	350	300	400	19	5,0	852	70	395	397	305	370	59,0	M20x42
Y2PE225S	4	356	286	149	60	140	18	225	19	400	350	450	19	5,0	874	75	435	445	335	395	64,0	M20x42
Y2PE225M	2 4/6	356 356	311 311	149 149	55 60	110 140	16 18	225 225	19 19	400 400	350 350	450 450	19 19	5,0 5,0	890 915	75 75	435 435	445 445	335 335	440 440	59,0 64,0	M20x42 M20x42
Y2PE250M	2 4/6	406 406	349 349	168 168	60 65	140 140	18 18	250 250	24 24	500 500	450 450	550 550	19 19	5,0 5,0	985 985	80 80	490 490	485 485	370 370	440 440	64,0 69,0	M20x42 M20x42
Y22PE280SZ-NE	2 4/6	457 457	368 368	190 190	65 75	140 140	18 20	280 280	24 24	500 500	450 450	550 550	19 19	5,0 5,0	1.045 1.045	85 85	550 550	547 547	410 410	480 480	69,0 79,5	M20x42 M20x42
Y22PE280MZ-NE	2 4/6	457 457	419 419	190 190	65 75	140 140	18 20	280 280	24 24	500 500	450 450	550 550	19 19	5,0 5,0	1.095 1.095	85 85	550 550	547 547	410 410	536 536	69,0 79,5	M20x42 M20x42
Y2PE315SZ-NE	2 4/6	508 508	406 406	216 216	65 80	140 170	18 22	315 315	28 28	600 600	550 550	660 660	24 24	6,0 6,0	1.185 1.220	120 120	635 635	620 620	530 530	570 570	69,0 85,0	M20x42 M20x42
Y2PE315MZ-NE	2 4/6	508 508	457 457	216 216	65 80	140 170	18 22	315 315	28 28	600 600	550 550	660 660	24 24	6,0 6,0	1.290 1.325	120 120	635 635	620 620	530 530	680 680	69,0 85,0	M20x42 M20x42
Y2PE315LZ-NE	2 4/6	508 508	508 508	216 216	65 80	140 170	18 22	315 315	28 28	600 600	550 550	660 660	24 24	6,0 6,0	1.290 1.325	120 120	635 635	620 620	530 530	680 680	69,0 85,0	M20x42 M20x42
Y2PE355MZ-NE	2 4/6	610 610	560 560	254 254	75 95	140 170	20 25	355 355	28 28	740 740	680 680	800 800	24 24	6,0 6,0	1.500 1.530	116 116	735 735	698 698	655 655	760 760	79,5 100	M20x42 M20x42
Y2PE355MZ-SWNE	4/6	610	560	254	100	210	28	355	28	740	680	800	24	6,0	1.570	116	735	698	655	760	106	M24x56
Y2PE355LZ-NE	2 4/6	610 610	630 630	254 254	75 95	140 170	20 25	355 355	28 28	740 740	680 680	800 800	24 24	6,0 6,0	1.500 1.530	116 116	740 740	698 698	655 655	760 760	79,5 100	M20x42 M20x42
Y2PE355LZ-SWNE	4/6	610	630	254	100	210	28	355	28	740	680	800	24	6,0	1.570	116	740	698	655	760	106	M24x56

# B34F1

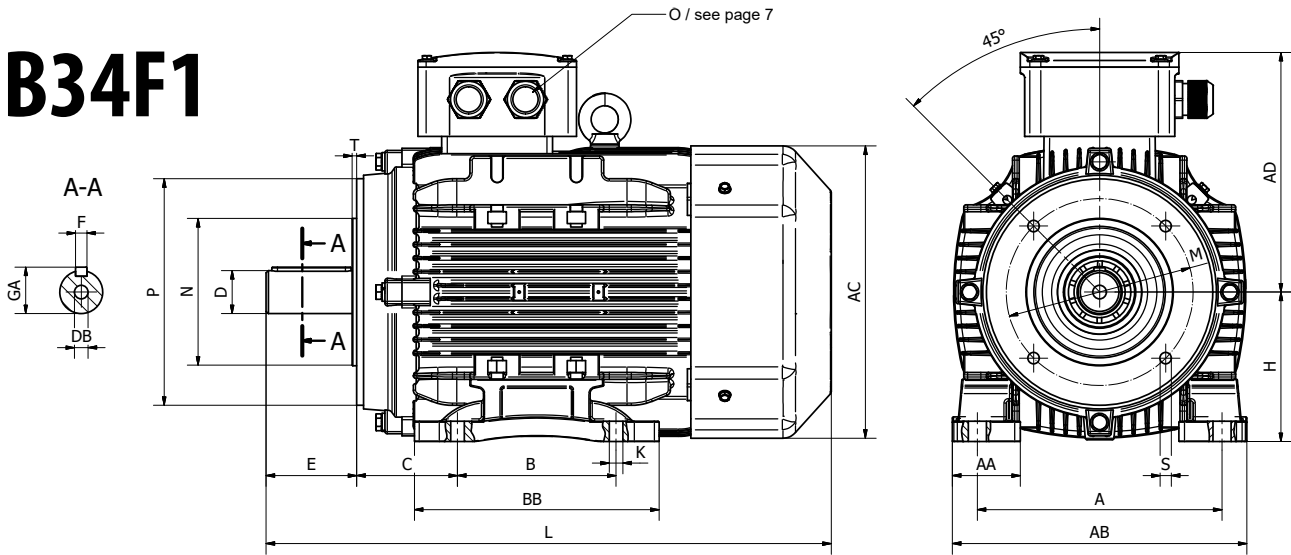

Frame size	poles	A	B	C	D	E	F	H	K	L	M	N	P	S	T	AA	AB	AC	AD	BB	GA	DB
80	2/4/6	125	100	50	19	40	6	80	10	299	100	80	120	M6	3,0	37	165	158	138	130	21,5	M6x16
90S	2/4/6	140	100	56	24	50	8	90	10	353	115	95	140	M8	3,0	37	180	177	152	140	27,0	M8x19
90L	2/4/6	140	125	56	24	50	8	90	10	373	115	95	140	M8	3,0	37	180	177	152	170	27,0	M8x19
100L	2/4/6	160	140	63	28	60	8	100	12	433	130	110	160	M8	3,5	40	205	197	180	190	31,0	M10x22
112M	2/4/6	190	140	70	28	60	8	112	12	461	130	110	160	M8	3,5	50	230	218	181	200	31,0	M10x22
132S	2/4/6	216	140	89	38	80	10	132	12	499	165	130	200	M10	3,5	60	260	258	212	216	41,0	M12x28
132M	2/4/6	216	178	89	38	80	10	132	12	522	165	130	200	M10	3,5	60	260	258	212	256	41,0	M12x28

# B34F2

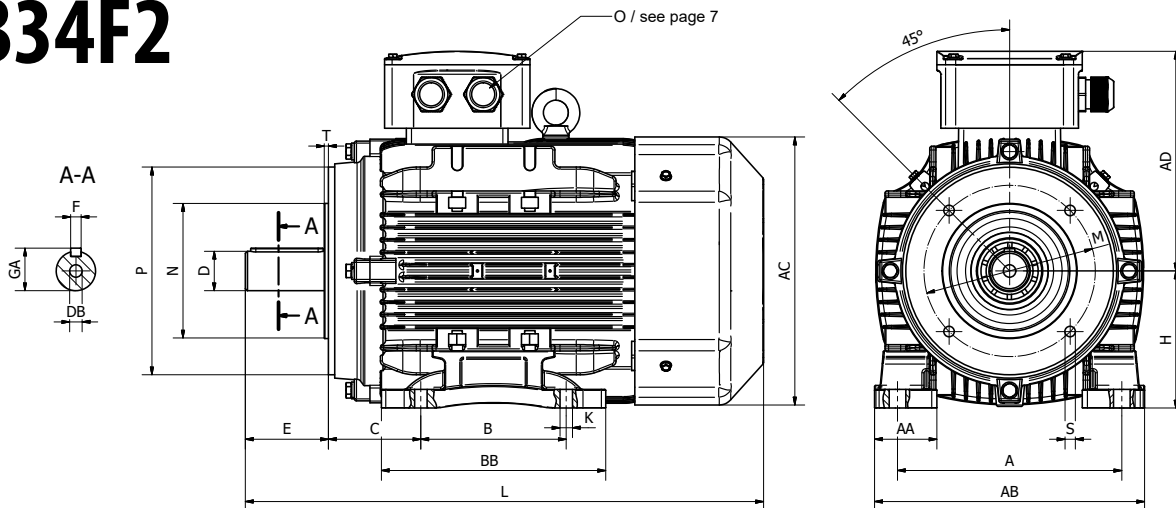

Frame size	poles	A	B	C	D	E	F	H	K	L	M	N	P	S	T	AA	AB	AC	AD	BB	GA	DB
80	2/4/6	125	100	50	19	40	6	80	10	299	130	110	160	M8	3,5	37	165	158	138	130	21,5	M6x16
90S	2/4/6	140	100	56	24	50	8	90	10	353	130	110	160	M8	3,5	37	180	177	152	140	27,0	M8x19
90L	2/4/6	140	125	56	24	50	8	90	10	373	130	110	160	M8	3,5	37	180	177	152	170	27,0	M8x19
100L	2/4/6	160	140	63	28	60	8	100	12	433	165	130	200	M10	3,5	40	205	197	180	190	31,0	M10x22
112M	2/4/6	190	140	70	28	60	8	112	12	461	165	130	200	M10	3,5	50	230	218	181	200	31,0	M10x22
132S	2/4/6	216	140	89	38	80	10	132	12	499	215	180	250	M12	4,0	60	260	258	212	216	41,0	M12x28
132M	2/4/6	216	178	89	38	80	10	132	12	522	215	180	250	M12	4,0	60	260	258	212	256	41,0	M12x28

# B5 / V1

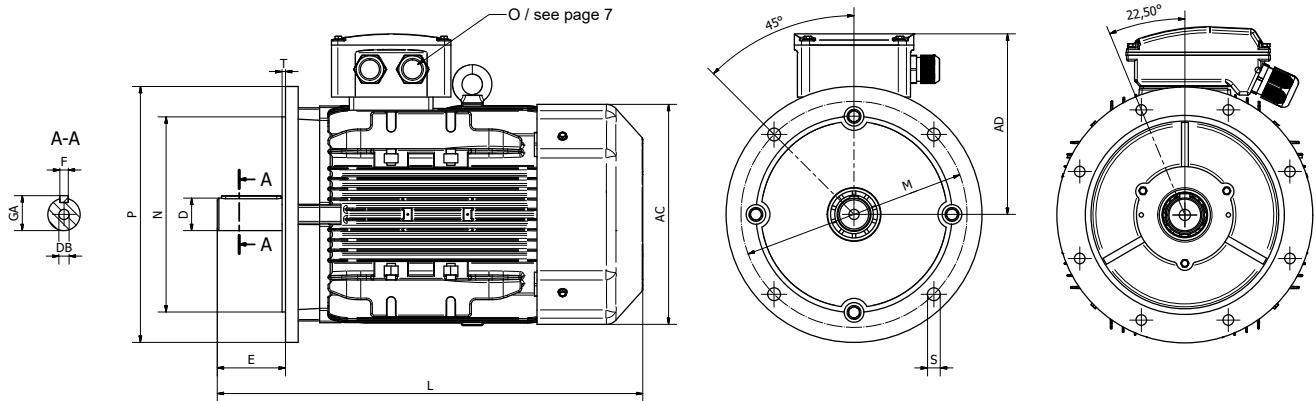

Frame size	poles	D	E	F	L	M	N	P	S	T	AC	AD	GA	DB
Y3PE80	2 / 4 / 6	19	40	6	299	165	130	200	12	3,5	158	138	21,5	M6x16
Y3PE90S	2 / 4 / 6	24	50	8	353	165	130	200	12	3,5	177	152	27,0	M8x19
Y3PE90L	2 / 4 / 6	24	50	8	373	165	130	200	12	3,5	177	152	27,0	M8x19
Y3PE100L	2 / 4 / 6	28	60	8	433	215	180	250	15	4,0	197	180	31,0	M10x22
Y3PE112M	2 / 4 / 6	28	60	8	461	215	180	250	15	4,0	218	181	31,0	M10x22
Y3PE132S	2 / 4 / 6	38	80	10	499	265	230	300	15	4,0	258	212	41,0	M12x28
Y3PE132M	2 / 4 / 6	38	80	10	522	265	230	300	15	4,0	258	212	41,0	M12x28
Y3PE160M	2 / 4 / 6	42	110	12	630	300	250	350	19	5,0	314	251	45,0	M16x36
Y3PE160L	2 / 4 / 6	42	110	12	677	300	250	350	19	5,0	314	251	45,0	M16x36
Y2PE160M	2 / 4 / 6	42	110	12	657	300	250	350	19	5,0	314	255	45,0	M16x36
Y2PE160L	2 / 4 / 6	42	110	12	725	300	250	350	19	5,0	314	255	45,0	M16x36
Y2PE180M	2 / 4 / 6	48	110	14	740	300	250	350	19	5,0	355	280	51,5	M16x36
Y2PE180L	2 / 4 / 6	48	110	14	810	300	250	350	19	5,0	355	280	51,5	M16x36
Y2PE200L	2 / 4 / 6	55	110	16	852	350	300	400	19	5,0	397	305	59,0	M20x42
Y2PE225S	4	60	140	18	874	400	350	450	19	5,0	445	335	64,0	M20x42
Y2PE225M	2 4 / 6	55 60	110 140	16 18	890 915	400 400	350 350	450 450	19 19	5,0 5,0	445 445	335 335	59,0 64,0	M20x42 M20x42
Y2PE250M	2 4 / 6	60 65	140 140	18 18	985 985	500 500	450 450	550 550	19 19	5,0 5,0	485 485	370 370	64,0 69,0	M20x42 M20x42
Y22PE280SZ-NE	2 4 / 6	65 75	140 140	18 20	1.045 1.045	500 500	450 450	550 550	19 19	5,0 5,0	547 547	410 410	69,0 79,5	M20x42 M20x42
Y22PE280MZ-NE	2 4 / 6	65 75	140 140	18 20	1.095 1.095	500 500	450 450	550 550	19 19	5,0 5,0	547 547	410 410	69,0 79,5	M20x42 M20x42
Y2PE315SZ-NE	2 4 / 6	65 80	140 170	18 22	1.185 1.220	600 600	550 550	660 660	24 24	6,0 6,0	620 620	530 530	69,0 85,0	M20x42 M20x42
Y2PE315MZ-NE	2 4 / 6	65 80	140 170	18 22	1.290 1.325	600 600	550 550	660 660	24 24	6,0 6,0	620 620	530 530	69,0 85,0	M20x42 M20x42
Y2PE315LZ-NE	2 4 / 6	65 80	140 170	18 22	1.290 1.325	600 600	550 550	660 660	24 24	6,0 6,0	620 620	530 530	69,0 85,0	M20x42 M20x42
Y2PE355MZ-NE	2 4 / 6	75 95	140 170	20 25	1.500 1.530	740 740	680 680	800 800	24 24	6,0 6,0	698 698	655 655	79,5 100	M20x42 M20x42
Y2PE355MZ-SWNE	4 / 6	100	210	28	1.570	740	680	800	24	6,0	698	655	106	M24x56
Y2PE355LZ-NE	2 4 / 6	75 95	140 170	20 25	1.500 1.530	740 740	680 680	800 800	24 24	6,0 6,0	698 698	655 655	79,5 100	M20x42 M20x42
Y2PE355LZ-SWNE	4 / 6	100	210	28	1.570	740	680	800	24	6,0	698	655	106	M24x56

# B14F1

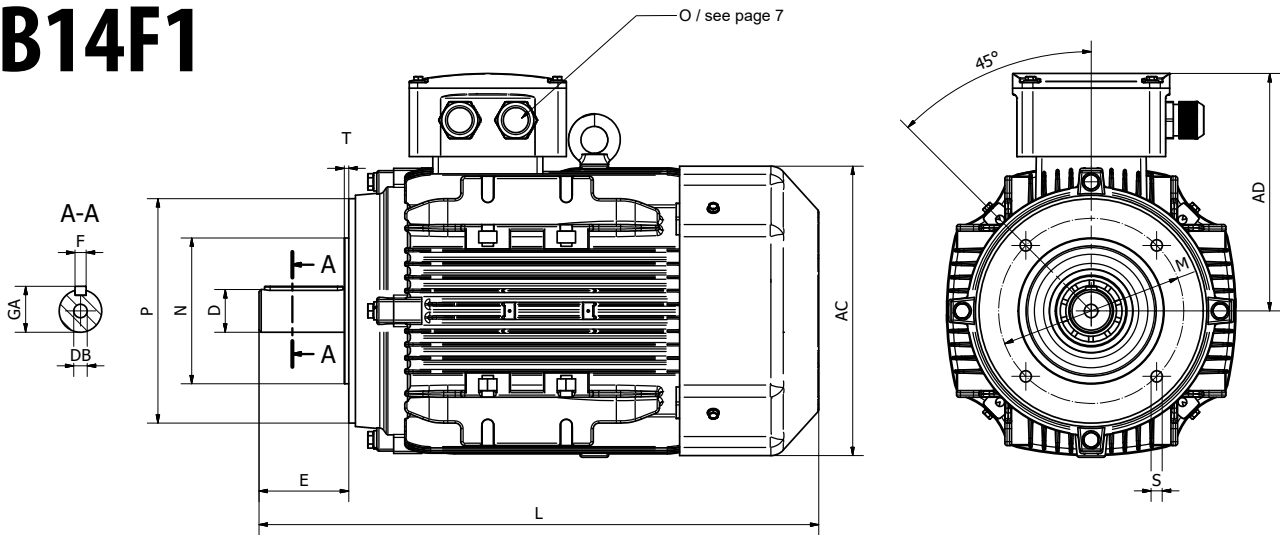

frame size	poles	D	E	F	L	M	N	P	S	T	AC	AD	GA	DB
80	2/4/6	19	40	6	299	100	80	120	M6	3,0	158	138	21,5	M6x16
90S	2/4/6	24	50	8	353	115	95	140	M8	3,0	177	152	27,0	M8x19
90L	2/4/6	24	50	8	373	115	95	140	M8	3,0	177	152	27,0	M8x19
100L	2/4/6	28	60	8	433	130	110	160	M8	3,5	197	180	31,0	M10x22
112M	2/4/6	28	60	8	461	130	110	160	M8	3,5	218	181	31,0	M10x22
132S	2/4/6	38	80	10	499	165	130	200	M10	3,5	258	212	41,0	M12x28
132M	2/4/6	38	80	10	522	165	130	200	M10	3,5	258	212	41,0	M12x28

# B14F2

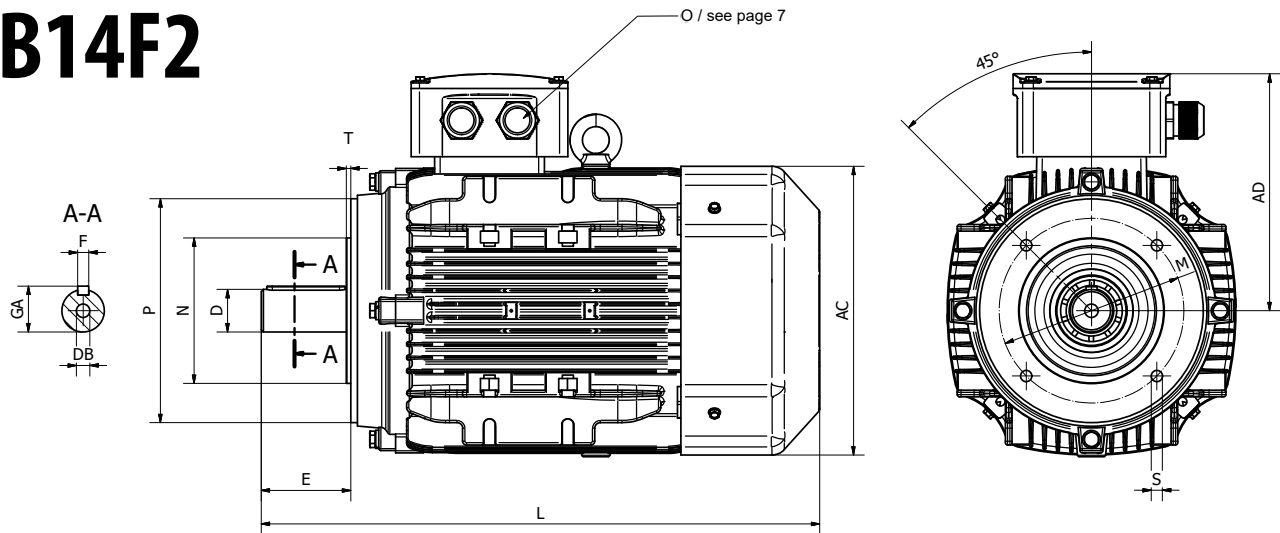

frame size	poles	D	E	F	L	M	N	P	S	T	AC	AD	GA	DB
80	2/4/6	19	40	6	299	130	110	160	M8	3,5	158	138	21,5	M6x16
90S	2/4/6	24	50	8	353	130	110	160	M8	3,5	177	152	27,0	M8x19
90L	2/4/6	24	50	8	373	130	110	160	M8	3,5	177	152	27,0	M8x19
100L	2/4/6	28	60	8	433	165	130	200	M10	3,5	197	180	31,0	M10x22
112M	2/4/6	28	60	8	461	165	130	200	M10	3,5	218	181	31,0	M10x22
132S	2/4/6	38	80	10	499	215	180	250	M12	4,0	258	212	41,0	M12x28
132M	2/4/6	38	80	10	522	215	180	250	M12	4,0	258	212	41,0	M12x28

## Available options with description

Z-UF	Special voltage and/or frequency (different as 230-400v or 400-690v/50hz)
Z-S2	Temporary duty xx min
Z-S3	Intermittent duty xx %
Z-TA	Execution for increased ambient temperature
Z-EA	Execution for altitude > 1000m above sea level
Z-LN	Neutrale name plate
Z-LK	Customer name plate
Z-LO	Customer related name plate
Z-LZ	Second additional name plate loose in the packaging
Z-LM	Metal name plate
Z-NT	Ambient temperature -40°c to -20°c
Z-IH	Winding insulation class h
Z-WF	Winding suitable for inverter duty
Z-WTI	Winding tropicalized
Z-WT	Water-repellent winding varnishing
Z-KT	Water-repellent motor-inside varnishing
Z-TG	Motor tropicalized
Z-VK	Encapsulated terminal box
Z-55	Ip55 protection
Z-56	Ip56 protection
Z-65	Ip65 protection
Z-66	Ip66 protection
Z-UB	Tenv (totally enclosed, not ventilated)
Z-VW	Fully encapsulated winding
Z-TM	Encapsulated motors ip67
Z-OK	Oil resistant insulation system
Z-WV	Viton shaft seals
Z-WD	Oil-tight shaft seal
Z-LD	Labyrinth seal de/nde
Z-VL	Forced bearing for increased radial load de
Z-SK	Angular ball bearing nde for increased axial load construction type v1
Z-IL	Insulated bearing nde
Z-FA	Locked bearing de adhesive bond
Z-FAS	Locked bearing de grooved ring
Z-FB	Locked bearing nde
Z-RS	Anti-run back device
Z-SL	Special bearing
Z-SKF	Skf bearing
Z-SPM	Spm bayonet catch de/nde
Z-NE	Greasing device
Z-KB	Drain holes de/nde
Z-SR	Stainless screws unpainted
Z-VB	Reduced balance grade b
Z-ZW	Double shaft extension
Z-SW	Customised shaft
Z-DK	Ptc protection
Z-DW	Ptc protection warning/switch off
Z-TO	Pto protection
Z-TS	Pts protection
Z-TOA	Pto protection/ single phase motor
Z-PW	Pt100 for winding monitoring
Z-KTY	Winding temperature measuring kty84-130
Z-PL	Pt100 for bearing monitoring de/nde
Z-PLA	Pt100 for bearing monitoring de
Z-PLB	Pt100 for bearing monitoring nde
Z-PL4	Pt100 for bearing monitoring de/nde (four-wire circuit)

Z-SH	Anti condensation heating 230v
Z-RD	Rain canopy
Z-TK	Fan cover for textile application
Z-xxxx	Other colour than ral7030
Z-0000	Clear lacquer coating
Z-EP	Epoxy paint ralxxxx
Z-CL	Outer chemical protective paint coat
Z-SF	Customised flange according description 2
Z-KR	Terminal box on the right side
Z-KL	Terminal box on the left side
Z-KGA	Terminal box nde
Z-KZB	Terminal box with second terminal board (inverter duty brake motor)
Z-GF	Removeable feet
Z-SA	Motor with cam switch
Z-SU	Motor with cam switch for both directions
Z-SD	Motor with star-delta-switch
Z-DU	Motor with star-delta-switch for both directions
Z-MS	Motor with motor protection switch
Z-KS	Motor with plug/switch-combination
Z-KG	Motor with mounted cable and plug
Z-KD	Cable connection
Z-KV	Metal cable glands
Z-LA	Stranded wire xx cm long without terminals and terminal box
Z-KAM	Motor with mounted cable
Z-FLD	Forced ventilation 3x400 v
Z-FLE	Forced ventilation 1x230 v
Z-DG	Rotary pulse encoder
Z-RE	Resolver
Z-SC	Sinus-cosinus encoder
Z-GD	Flameproof motor suitable zone 1 (ex eb) and 21 (ex tb/ip6x)
Z-NS	Flameproof motor suitable zone 2 (ex na)
Z-HE	Flameproof motor suitable zone 22 (ex tc/ip5x)
Z-PZ	Approval en 10204
Z-CS	Csa approval
Z-CSM	Csa/ul material approval
Z-UL	Ul approval
Z-CC	China energy label sticker
Z-GO	Gost approval (in the past gost)
Z-EG	Extended warranty
Z-KXXX	Customized execution (first three characters of customer name)
Z-Z	Special motor with multiple options according to item additional text
Z-PN	Ptc (xxx°c) post hoc built in
Z-SN	Winding protection by bi-metal switch closer xxx°c, post hoc built in
Z-ML	Metal fan
Z-MH	Metal fan cover
Z-MK	Metal terminal box
Z-SR	Special rotor for severe starting conditions
Z-HM	Iso. Ci h heatresistant housing
Z-MA	Marine version
Z-LG	Endshields cast iron

# MOTORS

## ① THREE PHASE MOTORS (IE1, IE2, IE3, IE4)

0,06 – 1.000 kW / frame size 56 – 560  
3.000/1.500/1.000/750/600/500 rpm  
also in other revolutions available

### SINGLE PHASE - MOTORS

0,09 – 3,0 kW / frame size 56 – 112  
3.000/1.500/1.000 rpm  
available also with rectified starting moment

### POLE-CHANGING MOTORS CONSTANT TORQUE

Frame size 63 – 355

### POLE-CHANGING MOTORS FOR CENTRIFUGAL APPLICATION

Frame size 63 – 355

## ② BRAKE MOTORS

0,09 – 37 kW, frame size 63 – 200  
3.000/1.500/1.000/750 rpm  
available also pole-changing and for stage technology

### MOTORS FOR HIGH AMBIENT TEMPERATURE

#### EXPLOSION-PROOF MOTORS

A Zone 21 & 22, ExnA II, Exe II, ExD(e) II  
0,12 – 132 kW, frame size 63 – 315  
3.000/1.500/1.000/750 rpm  
also as pole-changing motors deliverable

#### SLIP RING ROTOR MOTORS

15 – 315 kW, frame size 200 – 355  
1.500/1.000/750 rpm

#### CRANE MOTORS

#### MEDIUM & HIGH VOLTAGE MOTORS

#### HIGH FREQUENCY MOTORS

#### CIRCULAR SAW MOTORS

2,2 – 8 kW, 1.400/2.800 rpm

#### SMALL-POWER MOTORS

## BUILT-IN AND SPECIALMOTORS

### DC-MOTORS

0,24 - 112 kW, frame size 71 - 180  
also deliverable in larger power rating

### PERMANENT MAGNETS DC-MOTORS

30 - 4.400 W, frame size 63 - 90  
12/24/48/90/180 V

### SERVO MOTORS

### SHADED POLE MOTORS

### TORQUEMOTORS

### SPINDLEMOTORS

### WATERCOOLED MOTORS

### DIGITAL INVERTERMOTORS

0,37 - 22 kW

### ROTATING FREQUENCY CONVERTERS

## ③ DRUM MOTORS

0,025 – 132 kW  
Tape speed: 0,05 – 4,50 m/s  
Drum diameter:  
72/84/110/113/135/165/215/320/400/450/630/800mm

## ④ VIBRATORS

centrifugal force: 0 – 200.000 N  
3.000/1.500/1.000/750/600/500 rpm

### SYNCHRONOUS MOTORS

### SUBMERSIBLE MOTORS IP68

### RELUCTANCE MOTORS

### ROTATING FIELD MAGNETS

### COOLING FLUID PUMPS

### MOTOR SWITCH & MOTOR PROTECTION SWITCH

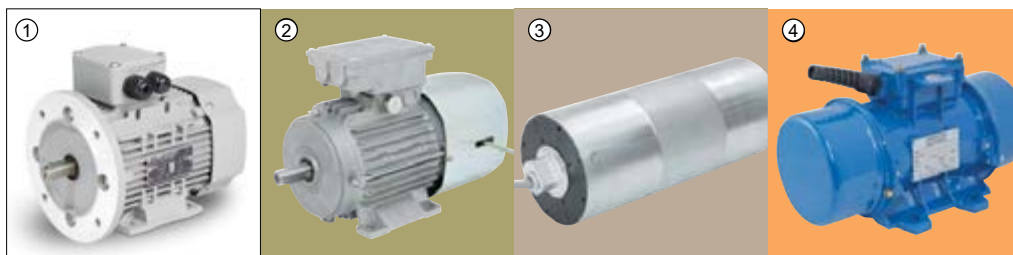



# GEARS

## ⑤ HELICAL GEARS AND -MOTORS (⚙️ too)

Torque range M2: 45 – 12.000 Nm

Gear ratios: 1:2,6 – 1:1.481



## ⑥ WORM GEARS AND -MOTORS (⚙️ too)

Torque range M2: 13 - 7.100 Nm

Gear ratios: 1:7 - 1:10.000



## ⑦ SHAFT MOUNTED GEARS AND -MOTORS (⚙️ too)

Torque range M2: 140 - 14.000 Nm

Gear ratios: 1:6,4 - 1:2.188



## ⑧ BEVEL GEARS AND -MOTORS (⚙️ too)

Torque range M2: 100 - 14.000 Nm

Gear ratios: 1:5,4 - 1:1.715

### BEVEL HELICAL GEARS AND -MOTORS

Torque range M2: 28.200 Nm - 210.000 Nm

Gear ratios: 5,6 – 400

## ⑨ PARALELL SHAFT GEAR UNITS AND -MOTORS

Torque range M2: 5000 - 21.000 Nm



### EXTRUDER GEARS AND -MOTORS

Torque range M2: 4650 Nm - 75.000 Nm

Gear ratios: 7,1 – 125

### SHAFT MOUNTED GEARS

Torque range M2: 150 - 16.000 Nm

Gear ratios: 1:5,0 - 1:31,5

### BEVEL GEARS

Torque range M2: 3 - 3.000 Nm

Gear ratios: 1:1,0 - 1:7,4

## ⑩ PLANETARY GEARS AND -MOTORS (⚙️ too)

Torque range M2: 1250 – 1286700 Nm

Gear ratios: 1:3,4 - 5234

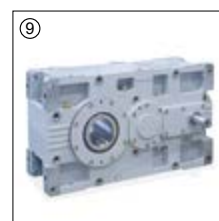

### PLANETARY GEARS FOR HYDRAULICMOTORS

### SMALL-POWER GEARMOTORS

### WORMGEAR SCREW JACKS AND -MOTORS

## ⑪ LOW BACKLASH GEARBOXES AND -MOTORS

Torque range M2: 12 - 1.000 Nm

Gear ratios: 1:3,0 (1-stage) / 1:1.000 (3-stages)



### SHADED POLE- / SMALL-POWERGEARS AND -MOTORS

### CUSTOMIZED SPECIALGEARS AND -MOTORS



# SPEEDVARIATORS / INVERTERS

## ① MECHANICAL SPEED VARIATORS AND -MOTORS

0,12 – 9,2 kW, adjustable range 1:5,5  
(reduction through a differential unit)

### SPEEDCONTROLLER FOR DC-MOTORS

0,01 – 3,7 kW

### SOFTSTARTER

single- and threephase

## ② DIGITAL INVERTERS

0,2 – 800 kW

## SERVODRIVE INVERTER

0,55 – 132 kW

## PHOTOVOLTAIC INVERTER

## DIGITAL INVERTERMOTORS

0,37 – 22 kW

## ENCODER

absolute and incrementale

## MAINS UNIT (feed-in/feed-back)

9,7 – 318 kVA, 14 – 460 A



# DRIVE COMPONENTS

## HYDRO DYNAMIC COUPLINGS

P 0,37 - 2.500 kW  
suitable for couplings- and belt-drive

## COUPLINGS

6 – 7.200.000 Nm

## ③ FLEXIBLE COUPLINGS

12 – 1.300.000 Nm

## TORQUE COUPLINGS

70 - 10.000 Nm

## ELECTROMAGNETIC BRAKE COUPLINGS

8 - 75 Nm

## ZERO BACKLASH STEEL COUPLINGS

0.1 - 46.000 Nm

## CONICAL CLAMPING ELEMENTS

14 - 365.000 Nm

## SCREW-ON HUBS AND WELD-ON-HUBS

Ø 105 – 350 mm

## V-BELT PULLEYS

Aluminium SPA, SPB, SPZ Ø 40 - 500 mm

## ④ V-BELT PULLEYS

Cast iron SPA, SPB, SPC, SPZ Ø 40 - 1.200 mm

## POLY-V-BELT PULLEY WITH TAPER-BUSH

Profile J,L,M Ø 62 - 720 mm

## TIMING PULLEY FOR TAPER BUSH

Ø 60 - 909 mm

## TIMING PULLEY MONOBLOCK

Ø 16 - 485 mm

## BELTS

## SPROCKETS AND WHEELS FOR TAPER BUSH

Ø 50 - 933 mm

## ⑤ MOTOR SLIDE RAILS

for frame sizes 63 - 355 motors

## ADJUSTABLE BASE PLATES



# GENERATORS

- ⑥ **SYNCHRONOUS ALTERNATORS**  
1,0 - 2.500 kVA . 3.000/1.500 rpm

**ASYNCHRONOUS ALTERNATORS**

**DC-ALTERNATORS**

**WINDALTERNATORS**  
0,4 - 5 kW

**400 Hz ALTERNATORS**

**WELDING ALTERNATORS**  
130 - 500 A, 4 - 15 kVA

**GENERATING SETS WITH PETROL-,  
DIESEL- AND GASENGINES**  
0,8 - 3000 kVA

- ⑦ **POWER TAKE-OFF DRIVEN GENERATORS**  
8,0 - 60 kVA

**WELDING GEN SETS**



**DYNAMIC VOLTAGE- AND  
FREQUENCY CONVERTERS**  
(for network simulation in test panels)

# SERVICES

**REPAIRS**

- ⑨ **REWINDINGS AND SPECIAL DESIGN**

**“SIEMENS”- SOLUTION PARTNER**  
(Standard Drives Motors - SIMOLOG)

**“SIEMENS”- SERVO MOTORS REPAIRS**  
SIMODRIVE RRC / SERCO

**DYNAMICALLY BALANCING UP TO 3 TONS**

**LASER-AIDED ALIGNMENT FROM COUPLINGS  
AND BELT TRANSMISSION** (also on-site service)

- ⑩ **BEARING- AND WINDING CONDITION MEASURING**  
(also on-site service)

**CUSTOMER SERVICE - INDUSTRIAL FACILITIES**

**CUSTOMER SERVICE - PUMPS**

**ENERGY EFFICIENCY CONSULTATION**

**CREATION OF MAINTENANCE SCHEDULES**

**DEVELOPMENT AND IMPLEMENTATION OF  
AUTOMATION PROJECTS**

**CONTROL- AND FEEDBACKSYSTEMS**

**AUTOMATION**

- ⑧ **PANELBUILDING**

**24h-SERVICE-HOTLINE 0900 150060**  
(only available for direct calls from Austria)

**EXPRESS-SERVICE**

**PICK-UP AND DELIVERY SERVICE**

24-hours-delivery guarantee for stock articles  
24-hours-delivery guarantee for  gears  
Just in time delivery by frame contracts  
Best price guarantee (same product of the same brand)

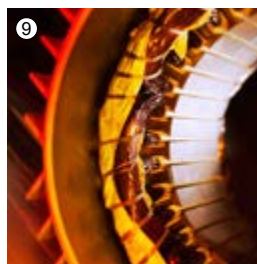

Spare parts for motor series Y3PE

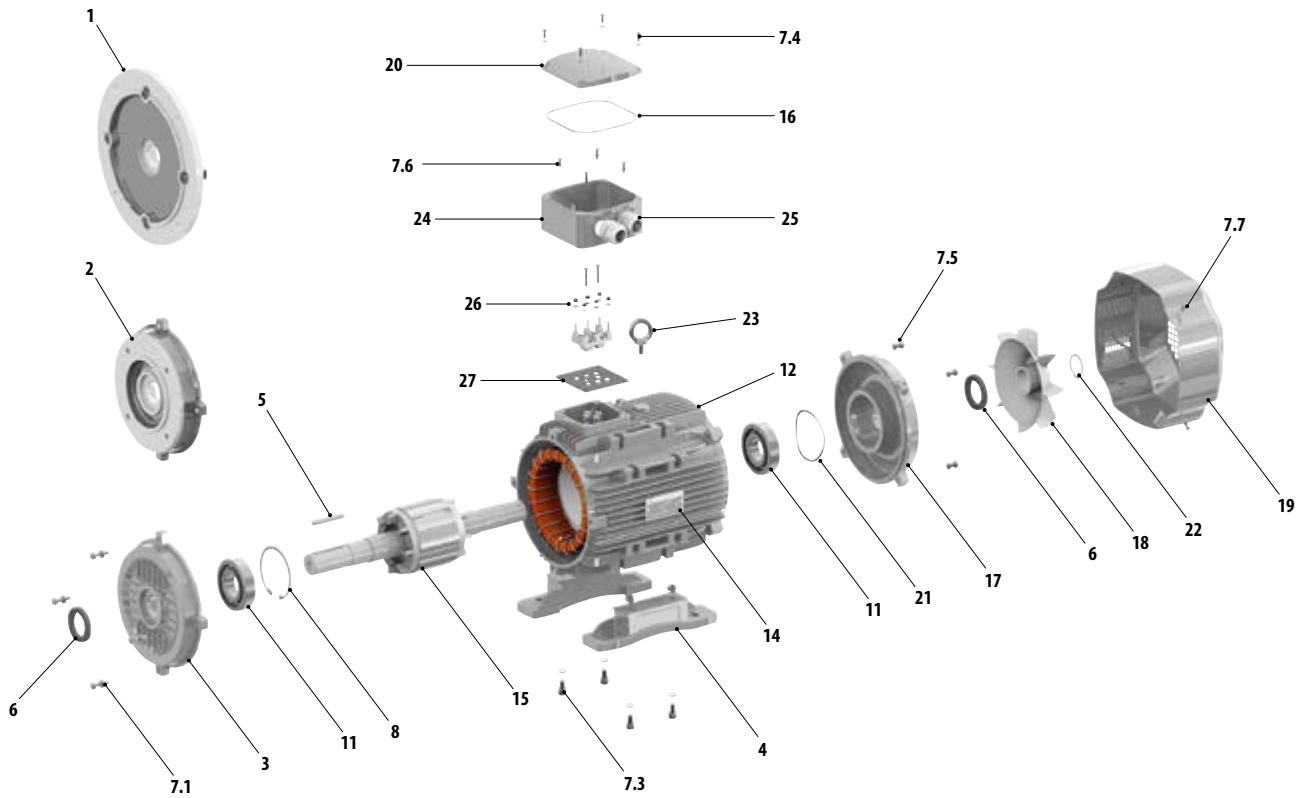

Spare parts for motor series Y2PE

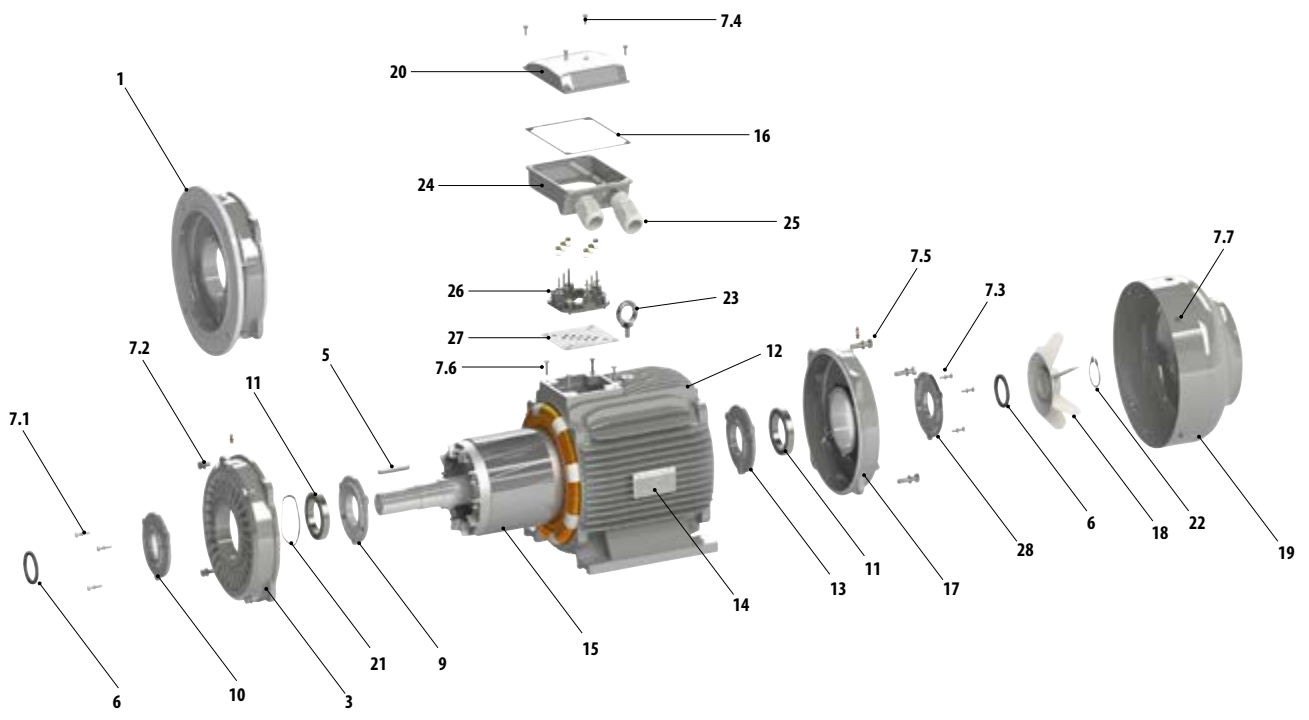





## MOLL-MOTOR Mechatronische Antriebstechnik GmbH

A-2000 Stockerau, Industriestraße 8

Phone: +43 2266 63421-0

Fax: +43 2266 63421-80

[office@mollmotor.at](mailto:office@mollmotor.at)

[www.mollmotor.at](http://www.mollmotor.at)

**Service-Hotline: 0900 150060\***

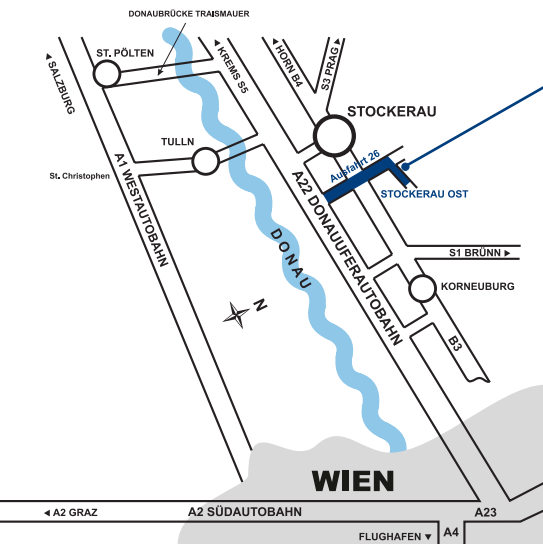

### Sales offices

#### Oberösterreich/Salzburg

A-4040 Linz, Colerusstraße 4

Phone: +43 2266 63421 201

Fax: +43 2266 63421 8201

Email: [vtbmitte@mollmotor.at](mailto:vtbmitte@mollmotor.at)

#### Tirol/Vorarlberg

Phone: +43 664 8349309

Email: [vtbwest@mollmotor.at](mailto:vtbwest@mollmotor.at)

#### Steiermark/Kärnten

Phone: +43 664 8349316

Email: [vtbsued@mollmotor.at](mailto:vtbsued@mollmotor.at)

#### POLEN

Phone: +48 (0) 61 6604 666

Email: [info@mollmotor.pl](mailto:info@mollmotor.pl)

#### DEUTSCHLAND

Phone: +49 (0) 6182 - 9467130

Fax: +49 (0) 6182 - 9467131

Email: [info@mollmotor.de](mailto:info@mollmotor.de)

# MOLL-MOTOR

All datas are subject to change without prior notice.

\*with costs – only available in Austria

