

A 352 - 353

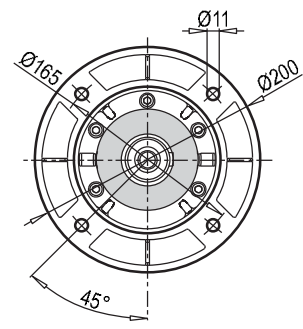
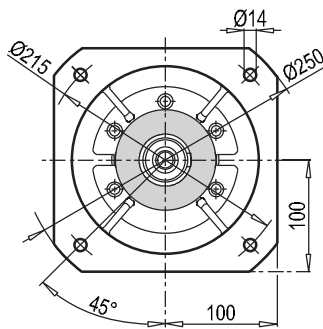
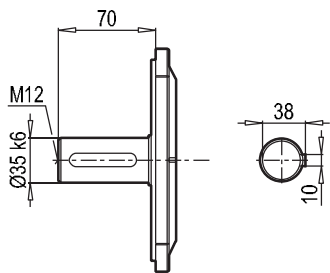
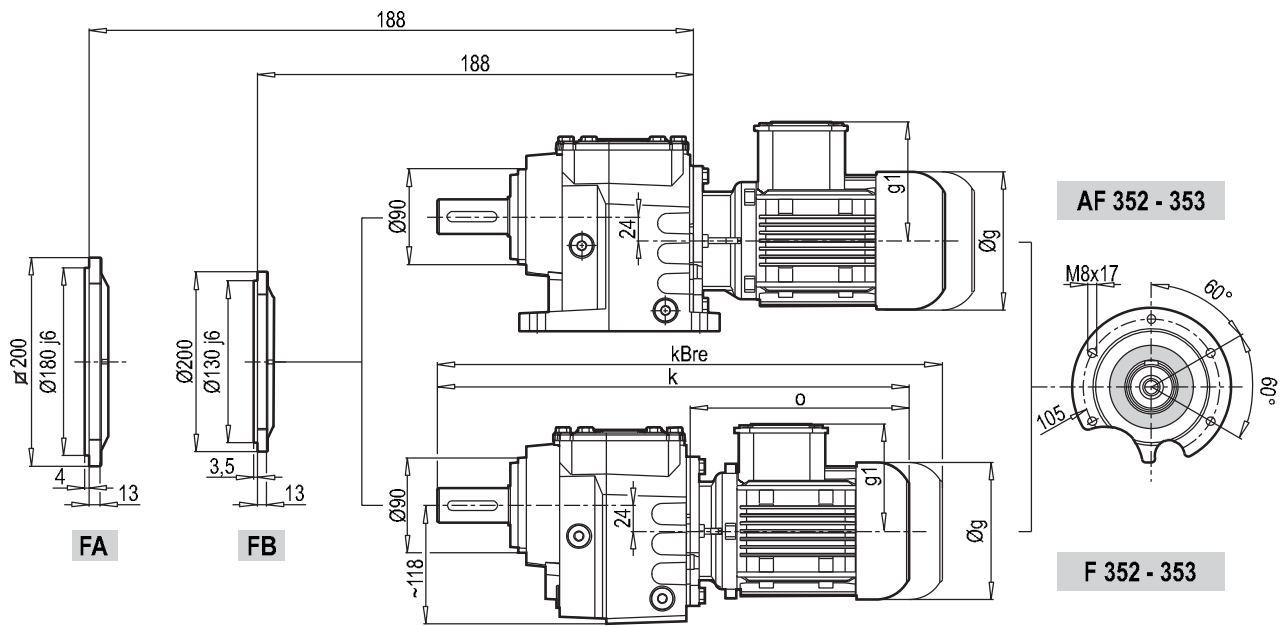
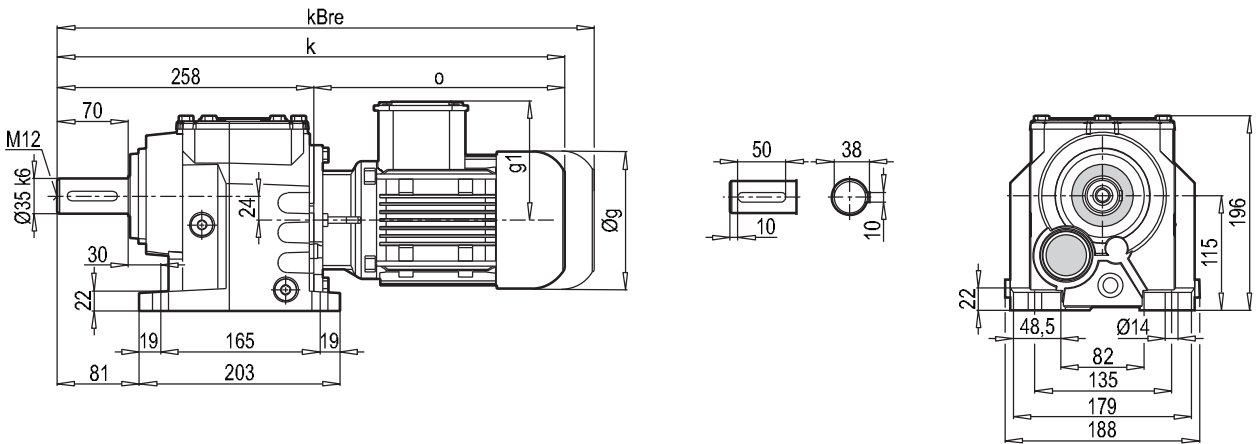

FA

FB

	63 M	71 M	80 M	90 S	90 L	100 L	112 M
g	124	140	159	193	193	217	232
g1	111	119	127	151	151	160	168
k	470	499	525	571	591	592	651
kBre	522	559	587	644	664	673	731
o	212	241	267	313	333	334	393

A - PAM

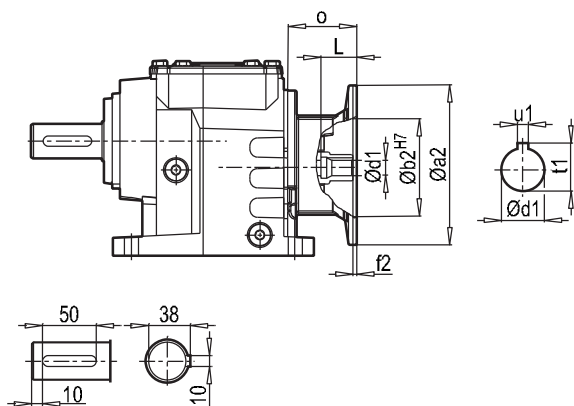

A - W

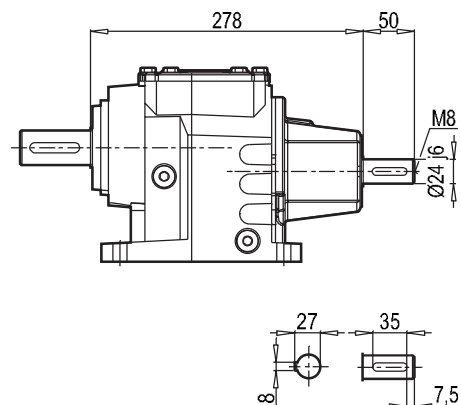

F - PAM

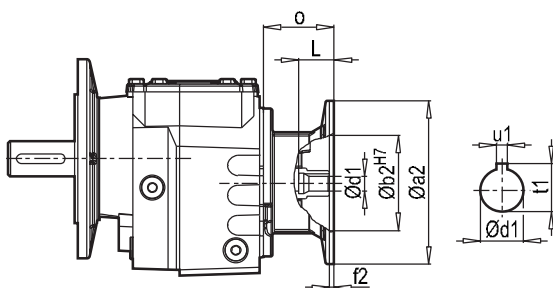

F - W

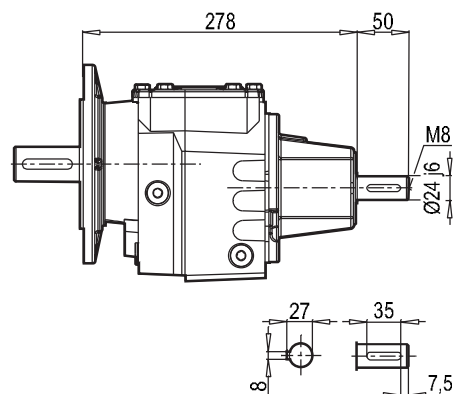

AF - PAM

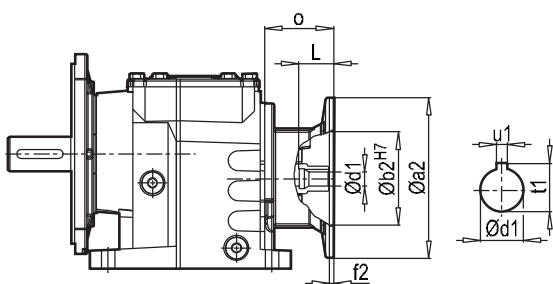

AF - W

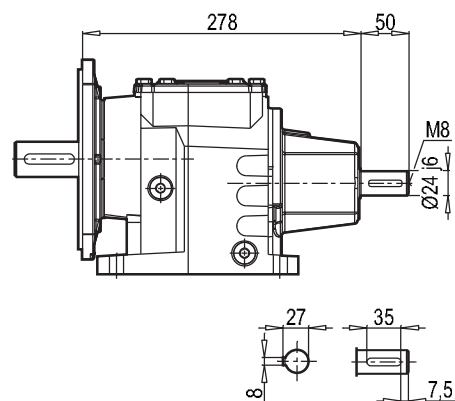

	63	71	80	90	100	112		
a2	140	160	200	200	250	250		
b2	95	110	130	130	180	180		
d1	11	14	19	24	28	28		
f2	4,5	5	5	5	5,5	5,5		
L	25	32	42	52	62	62		
u1	4	5	6	8	8	8		
t1	12,8	16,3	21,8	27,3	31,3	31,3		
o	57	69	90	90	105	105		